

PowerBoss®
The Power of Clean

Phoenix 20 Floor Scrubber Disc Traction Drive



PowerBoss, Inc.
A Member of The Hako Group

PREFACE

Thank you for your purchase of the new industry standard for scrubbers. PowerBoss takes great pride in offering the most dependable, reliable and best value in industrial power sweepers and sweeper / scrubbers. We set the standard.

Our Customer Service Department would like to hear from you. If you see any errors, omissions or something that needs clarification in this Parts Catalog please let us know. We are working hard towards continually improving our processes to bring you the best you deserve. Please copy the form below, fill out and comment on how you found our catalog.

Thank you!
The PowerBoss Team

Name: _____

Title: _____

Company Name: _____

Address: _____

Country: _____

Type of equipment or model number: _____

Comments: _____

Please return to:
Customer Service Manager
PowerBoss, Inc.
14N845 U.S. Route 20
Pingree Grove, Illinois 60140 USA

Phone: (800) 323-9420
Email: tech@powerboss.com

Technical Specifications

Model Phoenix 20 Traction Drive

Model No. PHX20TD / PHX20TDQP / PHX20TDQPG

Current (Max)	40 amps
Battery Capacity (Lead Acid)	140Ah @20 hr
Battery Capacity (Gel)	95Ah @20 hr
Sound Level	69 dBA
Cleaning path width	20 in (51 cm)
Squeegee width	34 in (86 cm)
Productivity (Traction Drive)	27,200 ft ² /hr (2,527 m ²)
Working speed (Traction Drive)	3.1 mph (5 km per hr)
Rated voltage	24 volts
Vacuum flow	65 cfm (110 m3/hr)
Vacuum waterlift	45 inches (112mbar)
Vacuum power	.60 HP (450 W)
Brush type	Disc
Brush motor(s) power	3/4 HP (560W)
Number of brushes	1
Brush RPM	180 RPM
Aqua-Stop equipped	Coming Soon
Solution capacity	12 Gal (45 liters)
Recovery capacity	13 Gal (49 liters)
Working Grade	2%
Weight with batteries	372 lbs (169 kg)
Weight without batteries	238 lbs (108 kg)
Dimensions (LxWxH)	47.4 x 21.3 x 42.3 (120.4 x 54.1 107.4 cm)
Drive Motor Power	1/5 HP (150W)

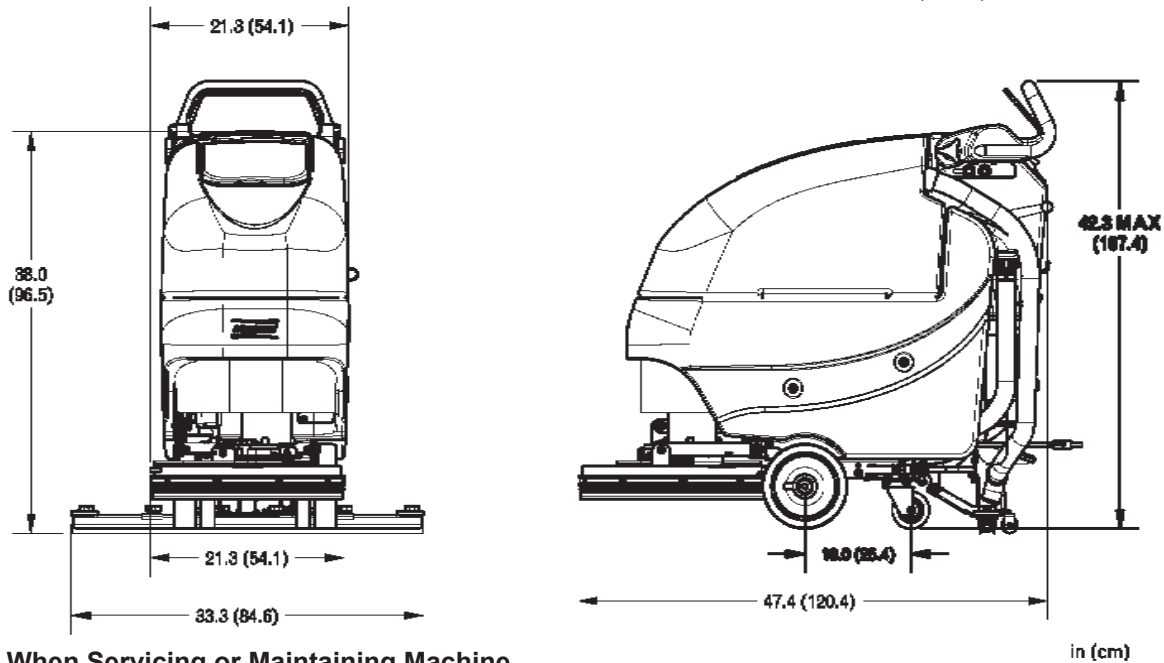

For Safety When Servicing or Maintaining Machine

- Stop on level surface.
- Disconnect the power to the machine by pulling the red Battery Connector located under the recovery tank near the batteries.
- Avoid moving parts. Do not wear loose jackets, shirts, or sleeves when working on machine.
- Avoid contact with battery acid. Battery acid can cause burns. When working on or around batteries, wear protective clothing and safety glasses. Remove metal jewelry. Do not lay tools or metal objects on top of batteries.
- Do not clean machine with a pressure washer.
- Authorized personnel must perform repairs and maintenance. Use PowerBoss supplied replacement parts.

Table of Contents

Phoenix 20 Floor Scrubber.....	1
Disc Traction Drive	1
Main Assembly	6
Main Assembly BOM.....	7
Traction Drive Base Assembly	8
Traction Drive Base Assembly BOM	9
Base Assembly.....	10
Base Assembly BOM.....	11
Chassis Assembly	12
Chassis Assembly BOM	13
Solenoid Assembly	14
Solution Valve Assembly	14
Solution Tank Assembly	15
Lift Pedal Stop Assembly.....	16
Battery Tray Assembly.....	17
Recovery Tank Assembly	18
Recovery Tank Assembly BOM	19
Handle Assembly.....	20
Handle Assembly BOM	21
Electrical Box Assembly	22
Electrical Box Assembly BOM	23
Electrical Box Cover Assembly.....	24
Vac Motor Assembly.....	25
20" Brush Deck Assembly	26
20" Brush Deck Assembly BOM.....	27
Brush Hub Assembly	29
Rear Squeegee Assembly.....	30
Rear Squeegee Assembly BOM.....	31
Squeegee Mechanism Assembly	32
Squeegee Mechanism Assembly BOM.....	33
Tension Band Sub-Assembly	34
Wiring Diagrams.....	35
Warranty.....	39

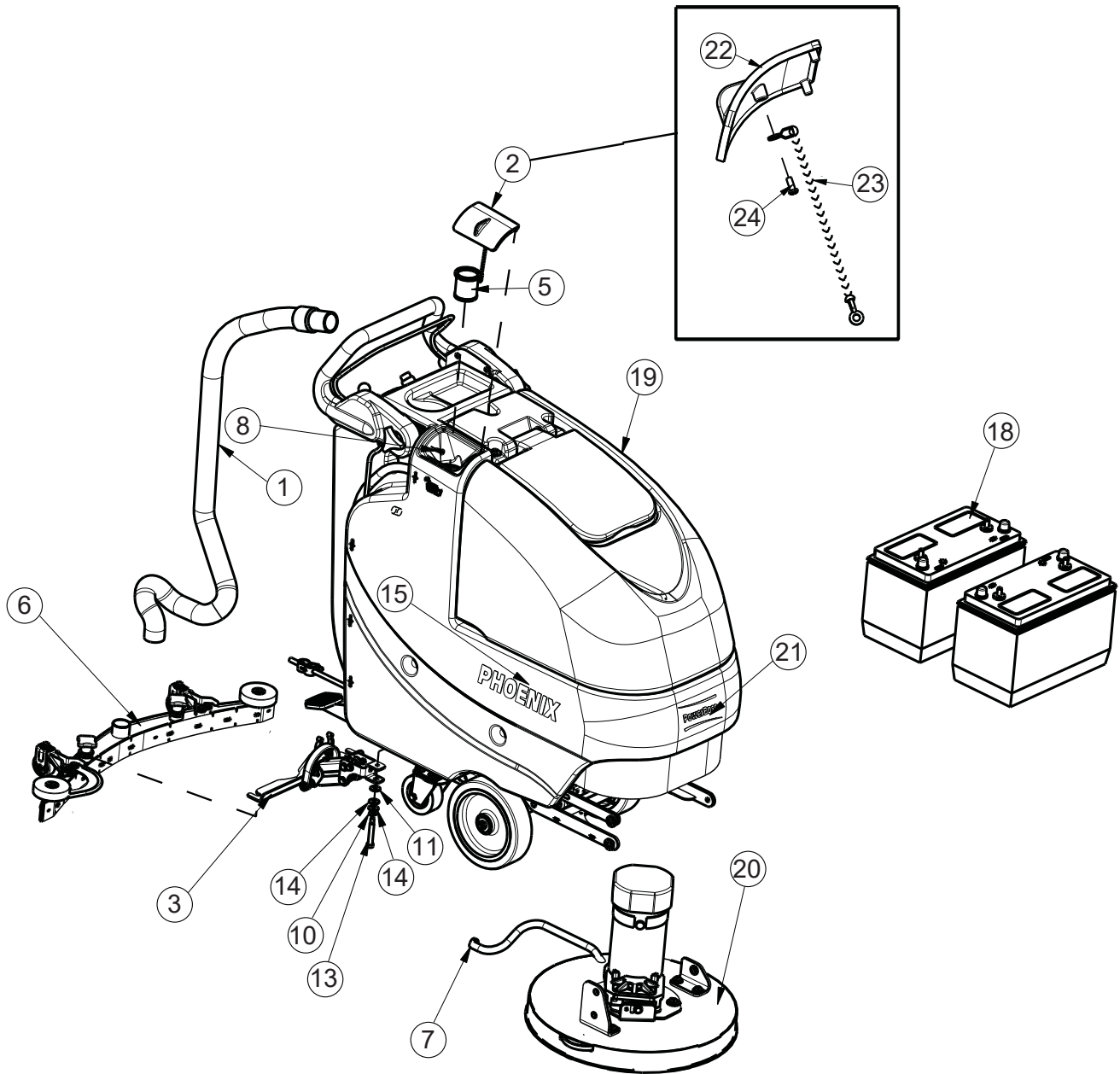

ITEM	PART NO.	QTY	DESCRIPTION
1	172010	1	HOSE, CLEAR VAC W/ 45 CUFF
2	172018	1	SOLUTION TANK LID ASSY
3	172150	1	SQUEEGEE LIFT MECH ASSY
5	172159	1	FILTER, FILL PORT, ES1720
6	172534	1	SQUEEGEE ASSY, 34" (860) CURVED
7	450076	1	CLAMP-CRIMP 185R SS
8	711118	1	SCR-ST-A 10 X .75 SS
10	711523	1	WSR-WAVE .37X .68 X .08
11	711569	1	WSR-FLT .390 X .880 X .062 NYL
13	712143	1	BLT-SHLD 3/8 X 2.0, 5/16-18
14	712301	2	WSR-FLAT .37 X .87 X .06
15	715688	2	DECAL, PHOENIX
16	740164-1	1	JUMPER CABLE ASSY, RED 4G 12"
17	747649	1	CABLE ASSY, BATTERY E17
18	956140	2	BATTERY, 12V 140AH
18A	956100	2	GEL BATTERY 12V 95AH
19	172001TD-120	1	TRAC DRV BASE ASSY-120V CHARGER
19A	172001TD-230	1	TRAC DRV BASE ASSY-230V CHARGER
20	172100TD	1	TD BRUSH DECK ASSY 20"
21	3334902	1	DECAL, POWERBOSS, WHITE
24	172008	1	SOLUTION TANK LID
25	172123	1	CHAIN, BEADED SS W/ EYELETS
26	712145	1	SCR-PAN HD HI/LO 6-19 X .37SS
23	715914W	1	DECAL, MINUTEMAN W/SWOOSHES, WHITE
24	172008	1	SOLUTION TANK LID
25	172123	1	CHAIN, BEADED SS W/EYELETS
26	712145	1	SCR-MC 6-32 X .37 PPH SS

BRUSH OPTIONS			
		AQUA STOP BRUSHES	
762394	PAD RETAINER, FIXED - NOT SHOWN	7951-01	BRUSH, 20" LIGHT-MED PP.5 A/S, WHITE
762370	PAD RETAINER, REMOVEABLE - NOT SHOWN	7951-02	BRUSH, 20" LIGHT-MEDIUM A/S, K901, BLACK
172520-1	BRUSH, 20" NYLON	7951-03	BRUSH, 20" MED NYL 600GR, A/S GREY (STANDARD)
172520-3	BRUSH-DISC, 20" NYLO-GRIT 80GR, GREEN	7951-04	BRUSH, 20" MEDIUM-HEAVY PP.8 A/S, WHITE
172520-6	DISC BRUSH 20", SCRUB GRIT 2, 120GR RED	7951-05	BRUSH, 20" HEAVY NYLON 180GR. A/S, GREY
172520-2	PAD DRIVER, 20"	7951-06	BRUSH, 20" HEAVY-2 NYL 120GR. A/S, GREEN

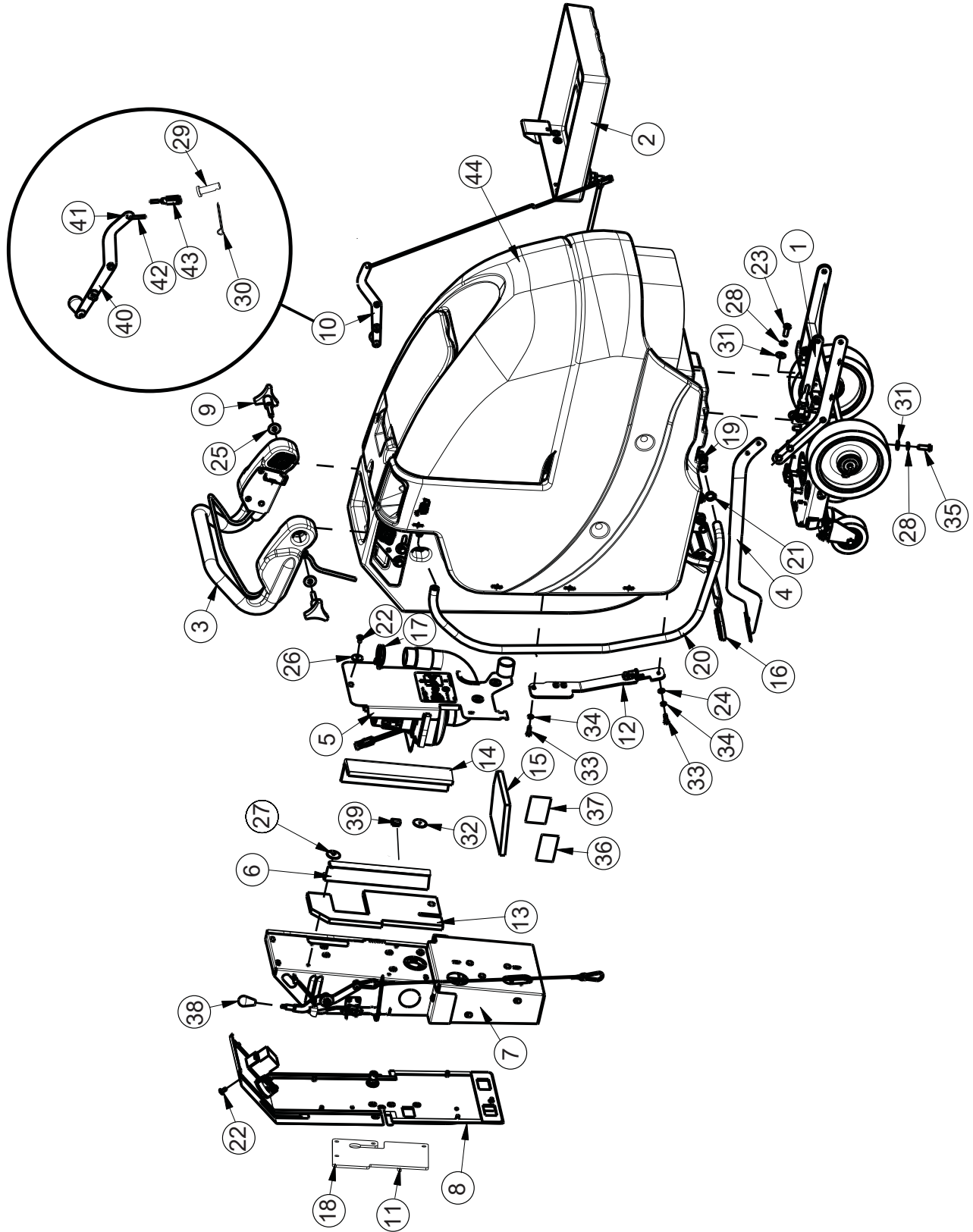

Traction Drive Base Assembly BOM

BILL OF MATERIAL - 172001TD - 120/230							
ITEM	PART NO	QTY	DESCRIPTION	ITEM	PART NO	QTY	DESCRIPTION
1	172009	1	TD CHASSIS ASSY, ES1720	23	710985	2	SCR-SC 3/8-16 X .62 ST PL
2	172012	1	BATTERY TRAY ASSY	24	711504	2	WSR-FLAT 1/4 ID SS
3	172015	1	E1720 TD HANDLE ASSY	25	711507	2	WSR-FLAT .37 X 1.12 X .06
4	172032	1	LIFT PEDAL WMT	26	711519	3	WSR- FLAT .25 X 1.01 X .06
5	172050	1	VAC MOTOR ASSY	27	711543	1	WSR-HELICAL #10
6	172055	1	BKT, VAC AREA INSIDE COVER	28	711546	6	WSR-HELICAL 3/8
7	172075-120	1	ELEC BOX TD ASSY 120V	29	711803	1	COTTER PIN-HAIR
8	172079	1	TD ELEC BOX COVER ASSY	30	712117	1	CLEVIS PIN
9	172085	2	KNOB, 3/8-16 STUD, 3 LOBE	31	712301	6	WSR-FLAT .37 X .87 X .06
10	172112	1	SOL CONTROL ASSY	32	712312	2	WSR-FLAT .187 X 1.25
11	172129	1	BKT, PWR CORD MOUNT	33	712562	2	BOLT-HH 1/4-20X3/4 SS
12	172166	1	TD LIFT PEDAL BKT ASSY	34	712758	2	WSR-HELICAL 1/4 SS
13	172184	1	FOAM COVER, REAR 1	35	713042	4	BLT-HH 3/8-16 X 1 #5
14	172185	1	FOAM COVER, REAR 2	36	715029	1	DECAL-NAME PLATE SERIAL
15	172187	1	FOAM COVER, FRONT 2	37	715047	1	DECAL-CLEAR LAMINATE 2X3
16	210142	1	PEDAL PAD	38	760592	1	KNOB, OVAL TAPERED
17	3303255	1	CLAMP-HOSE 1.75 DIA NOMINAL	39	809443	1	CLIP-WIRE & CORD
18	293080	1	STRAIN RELIEF-HEYCO 1207	40	172115	1	SOL CNTRL LEVER ASSY
19	342440	1	FITTING, TEE 3/4MPT 1/2 BARB PP	41	172122	1	NUT, PUSH-ON WSR CAP, 3/16
20	430156	1	HOSE, 1/2 X 42 CLEAR	42	172069	1	ROD, SOL. CTRL, ES1720
21	450093	2	CRIMP CLAMP 3/4" STEPLESS	43	172062	1	YOKE, 3/16 CLEVIS, 10-32, LONG
22	710178	10	SCR-MC 1/4-20 X .50 TRUSS STPL	44	172001BASE	1	ES1720 BASE ASSY

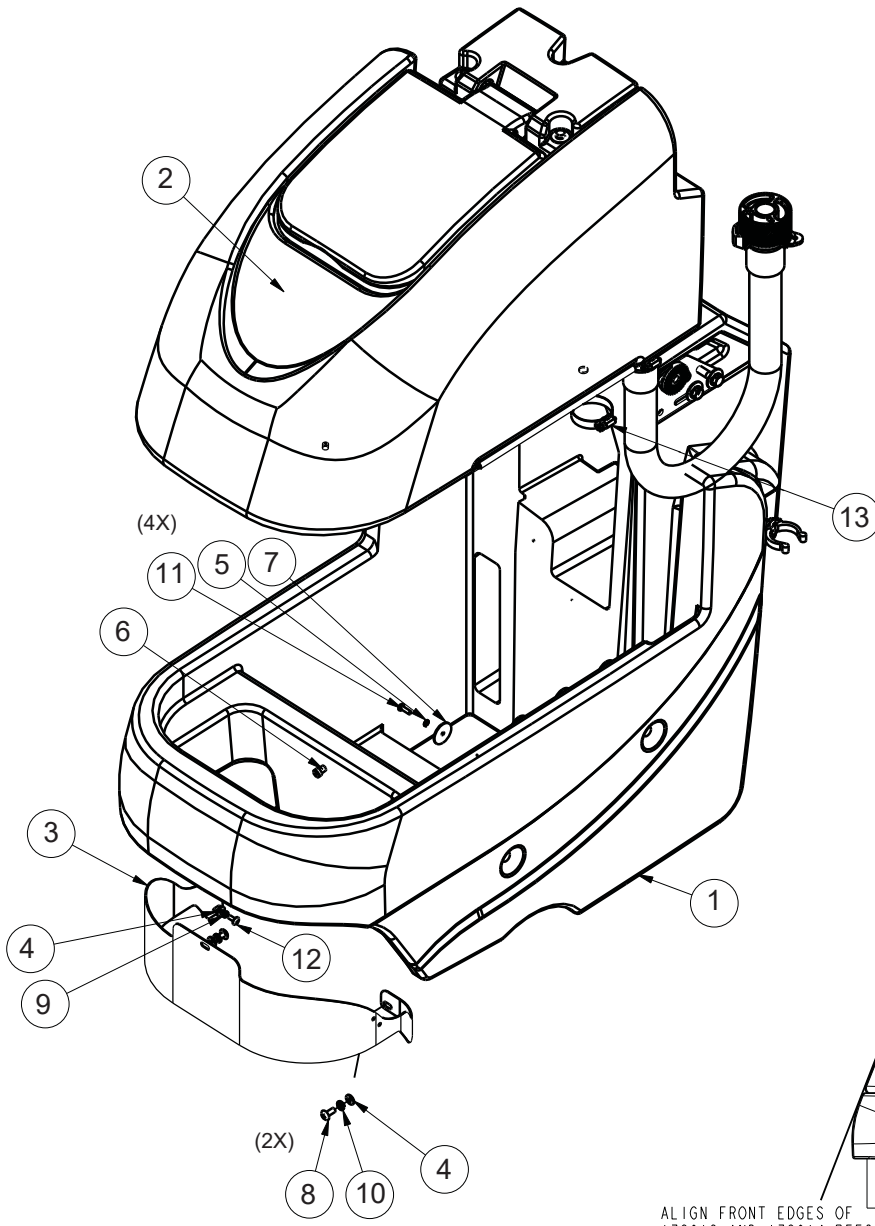

ALIGN FRONT EDGES OF
172013 AND 172014 BEFORE
TIGHTENING SCREWS FOR HINGE

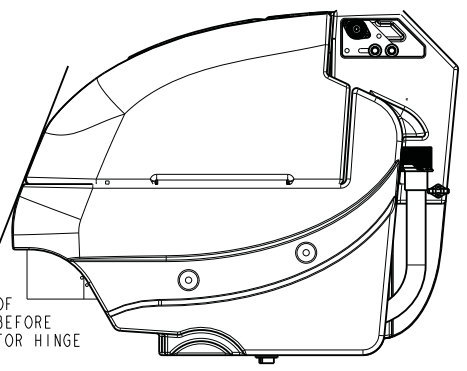

BILL OF MATERIAL - 172001BASE			
ITEM	PART NO.	QTY	DESCRIPTION
1	172013	1	SOLUTION TANK ASSY
2	172014PB	1	RECOVERY TANK ASSEMBLY
3	172144	1	COVER, FRONT PANEL E1720
4	711504	3	WASHER-FLAT 1/4 SS
5	711543	4	WASHER-LOCK #10 SPLIT ZP
6	712041	1	BLT-SHOULDER 5/16 X .375 LG X 1/4-20 BLK
7	712312	4	WASHER-BALANCING .187 X 1.25
8	712565	2	SCR-THMS 1/4-20 X .62 SS
9	712757	1	WASHER-LOCK #10 SPLIT SS
10	712758	2	WASHER-LOCK 1/4 SPLIT SS
11	712812	4	SCR-PHMS 10-24 X .62 ZP
12	712822	1	SCR-THMS 10-24 X .50 SS
13	3303255	1	CLAMP-HOSE 1.75 DIA NOMINAL

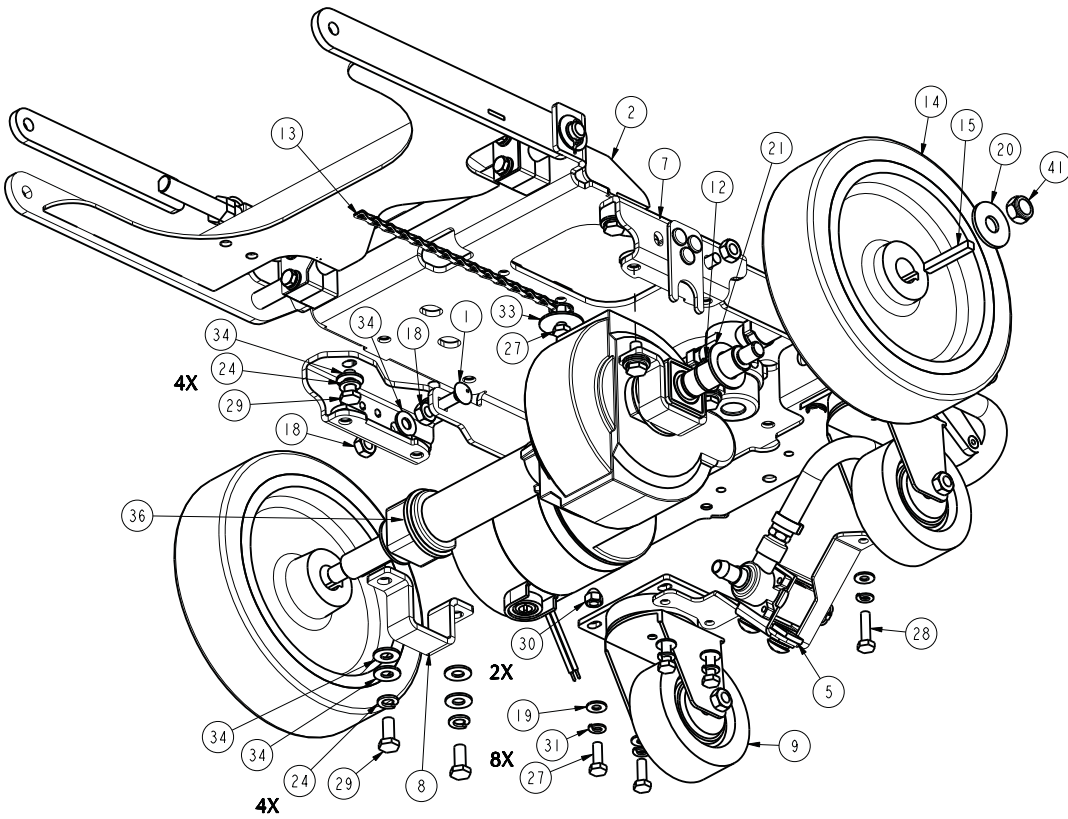
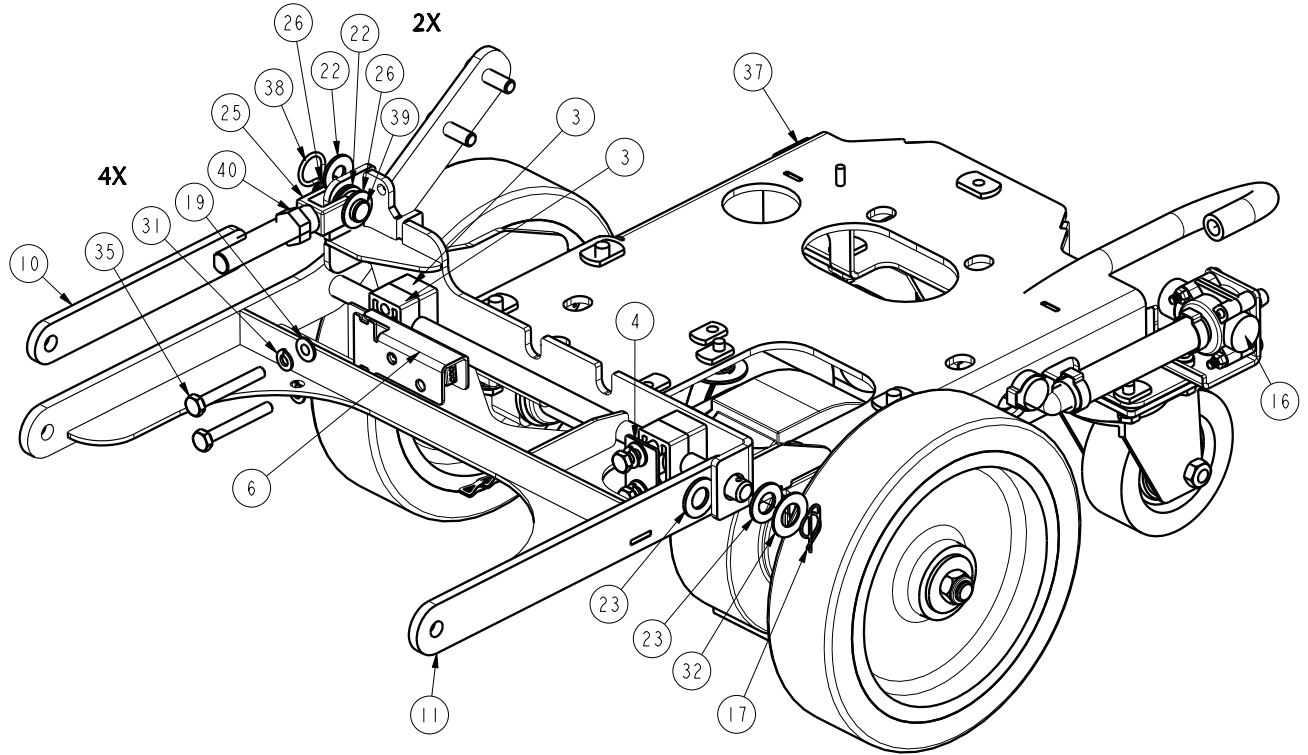

BILL OF MATERIAL - 172009			
ITEM	PART NO.	QTY	DESCRIPTION
1	70-516-16	2	BLT-CARR 5/16-18 X 1 ZP
2	172020	1	E1720 MAIN FRAME WMT
3	172038	4	BEARING BLOCK
4	172039	1	BEARING BLOCK PLATE
5	172104	1	SOLENOID MOUNT ASSY
6	172110	1	DECK SWITCH ASSY
7	172113	2	BKT, TRANSAXLE MOUNT BASE
8	172114	2	BKT, TRANSAXLE MOUNT
9	172167	2	CASTER, 3 1/2" PU WHEEL
10	172368	1	UPPER LIFT ARM
11	172370	1	DISC DECK LIFT WMT, E1720
12	172425	2	RING-RET EXT .75/20mm HD
13	172516	1	DRAG CHAIN, SS, 8" W/ RING
14	172518	2	WHEEL, 8X2 PU GROOVED
15	172519	2	KEY-SQUARE 6MM X 45MM
16	172571	1	ASSY-SOLUTION VALVE E1720
17	600578	1	RING-RUE .50 ZP
18	711383	4	NUT-HEX 5/16-18 ZP REVERSE LOC
19	711504	12	WASHER-FLAT 1/4 SS
20	711510	2	WASHER-FLAT 1/2 X 1.37 X .10 ZP
21	711512	2	WASHER-FLAT 3/4 X 1.37 X .08 ZP
22	711569	3	WASHER-FLAT .390 X .880 X .062 NYL
23	711592	2	WASHER-FLAT 1/2 X .90 X .064 NYLON
24	712140	8	WASHER-LOCK 5/16 SPLIT SS
25	712265	1	CLEVIS-YOKE, 1/2-20 WITH .375 PIN
26	712301	2	WASHER-FLAT 3/8 X .87 X .06 ZP
27	712562	8	SCR-HH 1/4-20 X .75, 18-8 SS
28	712564	1	SCR-HH 1/4-20 X 1.00 SS
29	712575	8	SCR-HH 5/16-18 X .75 18-8 SS
30	712591	2	NUT-ACORN 1/4-20 SS
31	712758	12	WASHER-LOCK 1/4 SPLIT SS
32	712760	1	WASHER-FLAT .56 X 1.06 X .04 SS
33	712761	1	WASHER-FENDER 1/4 X 1.25 X .059 SS
34	712772	14	WASHER-FLAT .344 X .75 X .06 SS
35	713007	4	SCR-HH 1/4-20 X 2.00 ZP GR 5
36	747606	1	TRANSAXLE, E1720 24V
37	809444	1	CLIP-CORD
38	833374	1	PIN-HAIRPIN COTTER 3/8
39	833833	1	PIN-CLEVIS 3/8 X 1.25
40	3400449	1	NUT-JAM 1/2-20 ZP
41	12040077	2	NUT-NYLOC M12 X 1.75 ZD CLASS 8

Solenoid Assembly

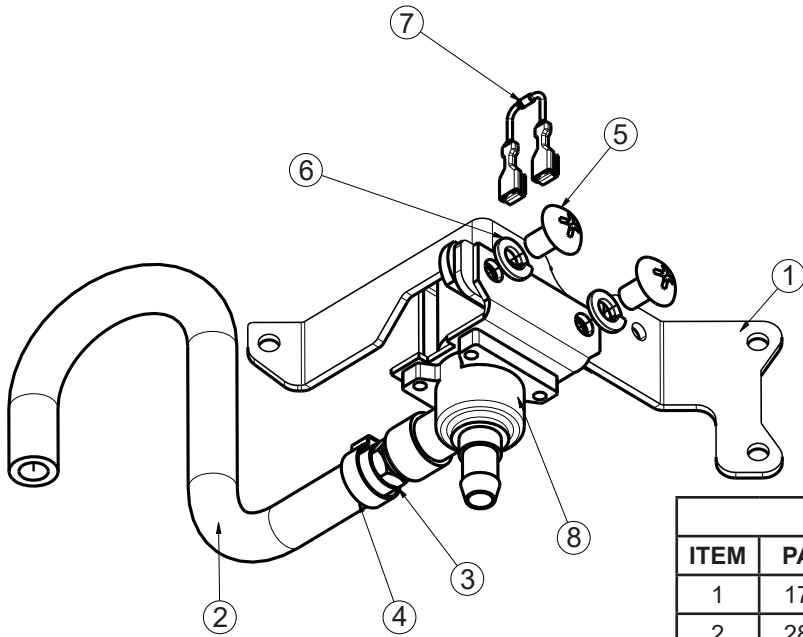

BILL OF MATERIAL - 172104			
ITEM	PART #	QTY	DESCRIPTION
1	172105	1	BKT, SOLENOID MOUNT
2	281637	1	HOSE-WIRE REINF 3/8 X 11"
3	320264	1	FTG-ADAPTER 1/4 MPT X 1/4 HB BRASS
4	450076	1	CLAMP-HOSE 5/8 (.590-.791) SS
5	710195	2	SCR-PHMS 5/16-18 X .50 ZP
6	711545	2	WASHER-LOCK 5/16 SPLIT ZP
7	740482	1	DIODE ASY, 1N4007 W/PIGGY
8	740493	1	VALVE-WATER 24VDC

Solution Valve Assembly

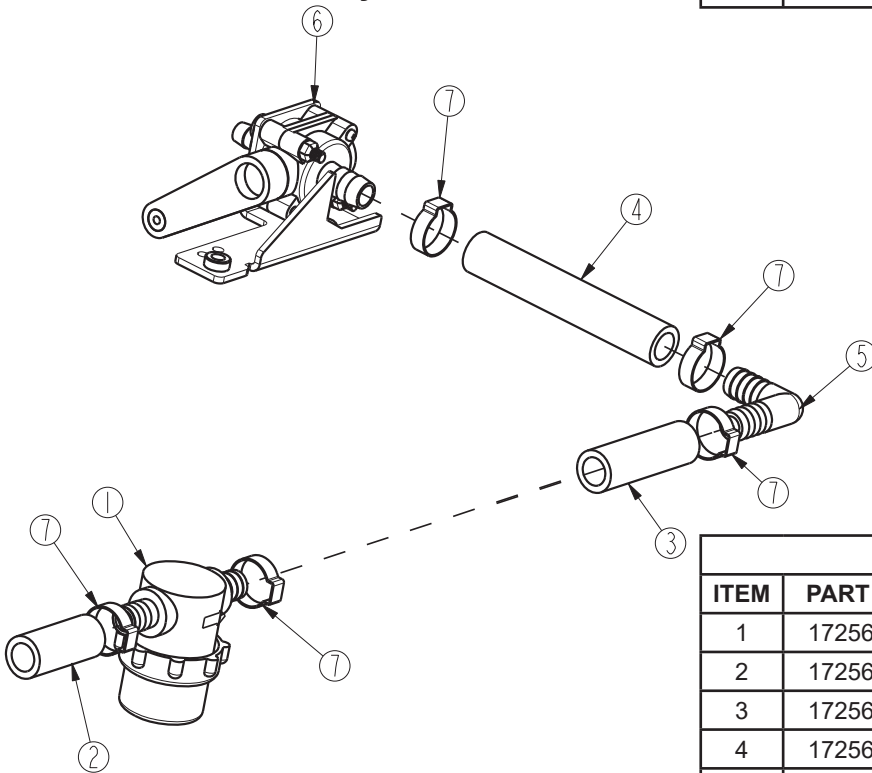

BILL OF MATERIAL - 172571			
ITEM	PART #	QTY	DESCRIPTION
1	172564	1	FILTER-SOLUTION E1720
2	172566	1	HOSE- 1/2"ID X 1.75" NYLOBRAID
3	172567	1	HOSE-1/2"ID X 2.375" NYLOBRAID
4	172568	1	HOSE-WIRE REINF 1/2"ID X 4.25"
5	172569	1	FTG-ELBOW 90 1/2 HB X 1/2 HB NYLON
6	172579	1	SOLUTION CNTRL VALVE, WITH BRKT
7	383347	5	CLAMP-CRIMP 1/2 HOSE

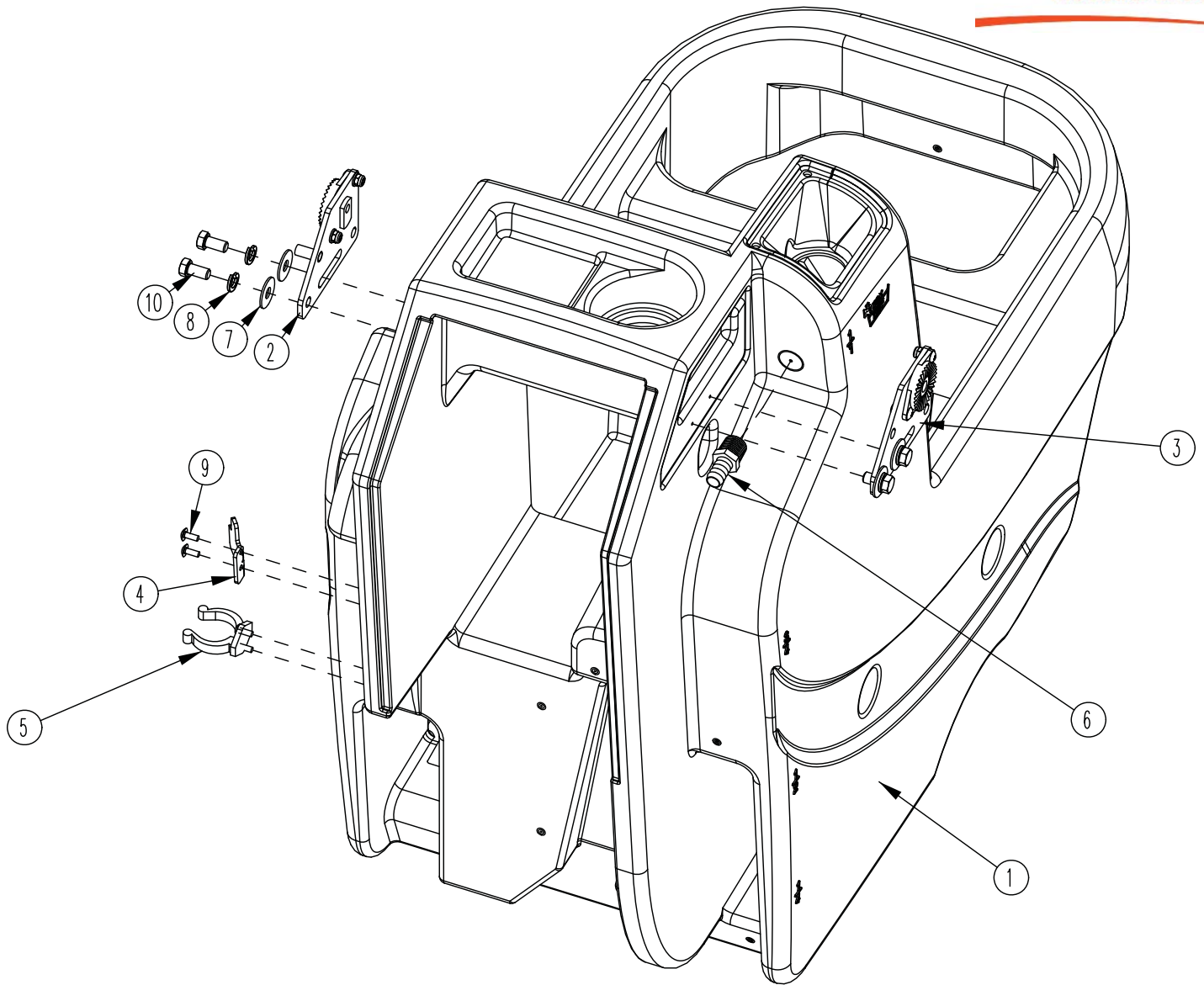

BILL OF MATERIAL - 172013			
ITEM	PART NO.	QTY	DESCRIPTION
1	172003	1	SOLUTION TANK
2	172080	1	HANDLE MOUNT ASSY, LEFT
3	172082	1	HANDLE MOUNT ASSY, RIGHT
4	172341	1	HOOK, DRAIN HOSE WITH TWIST VALVE
5	260579	1	TOOL CLIP, 1.5" HOSE
6	342438	1	FITTING, 1/2 MPT 1/2 HB BRASS
7	711507	4	WSR-FLAT .37 X 1.12 X .06
8	711546	4	WSR-HELICAL 3/8
9	712822	4	SCR-MC TR HD 10-24 X .50 SS
10	713041	4	BLT-HH 3/8-16 X 3/4 #5

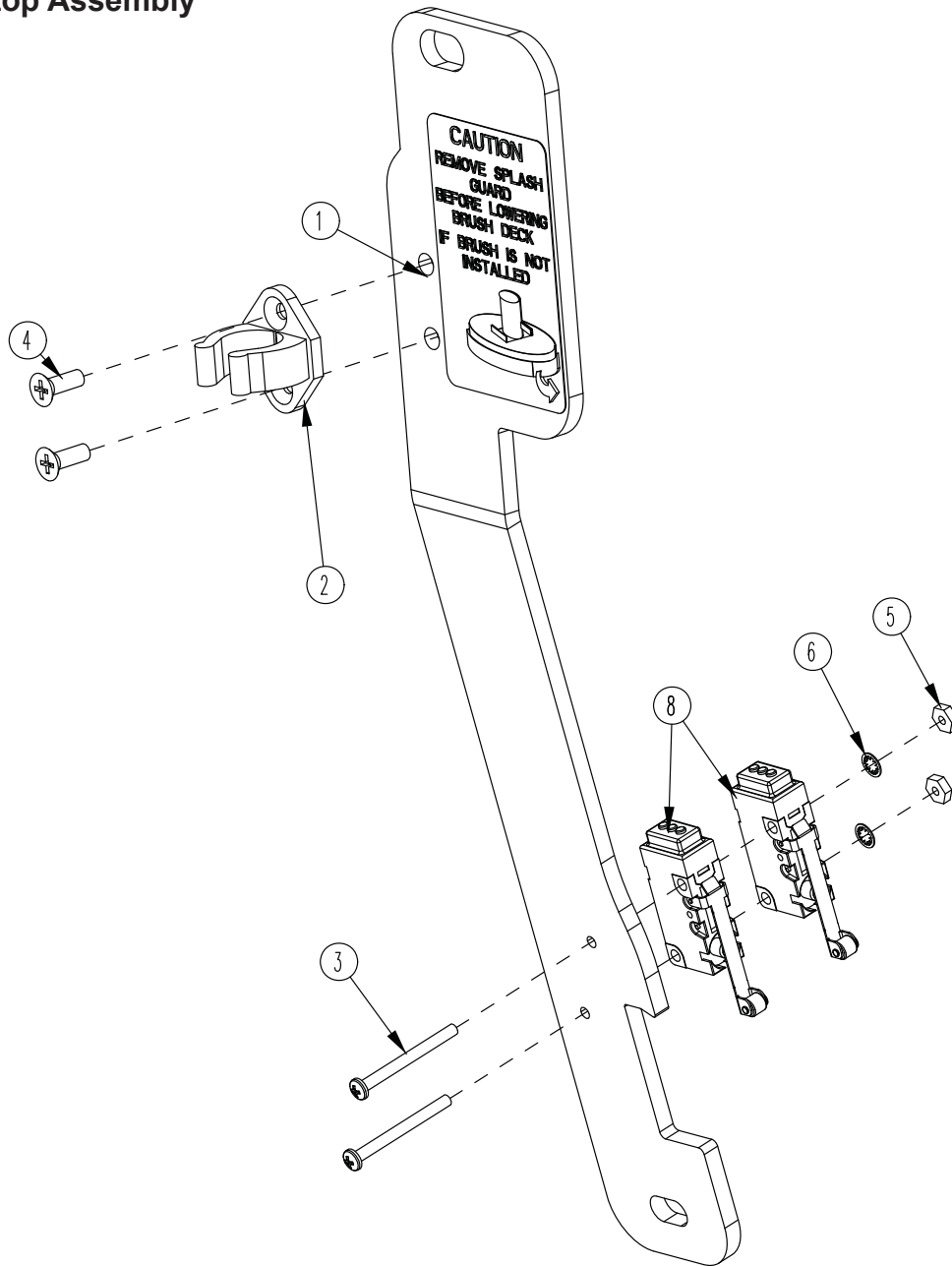

BILL OF MATERIAL - 172166			
ITEM	PART NO.	QTY	DESCRIPTION
1	172036	1	BKT, PEDAL STOP
2	172065	1	CLIP, FOR 1/2" ID HOSE
3	710495	2	SCR-MC 4-40 X 1.25 STL Z
4	710530	2	SCR-MC FL HD 8-32 X .50 BRS
5	711428	2	NUT-HEX 4-40
6	712326	2	WSR-INT LOCK #4
7	715685	1	DECAL, REMOVE SPLASH GUARD
8	747603-2	2	SWITCH ASY, MICRO ROLLER W/PACK/CONDUIT

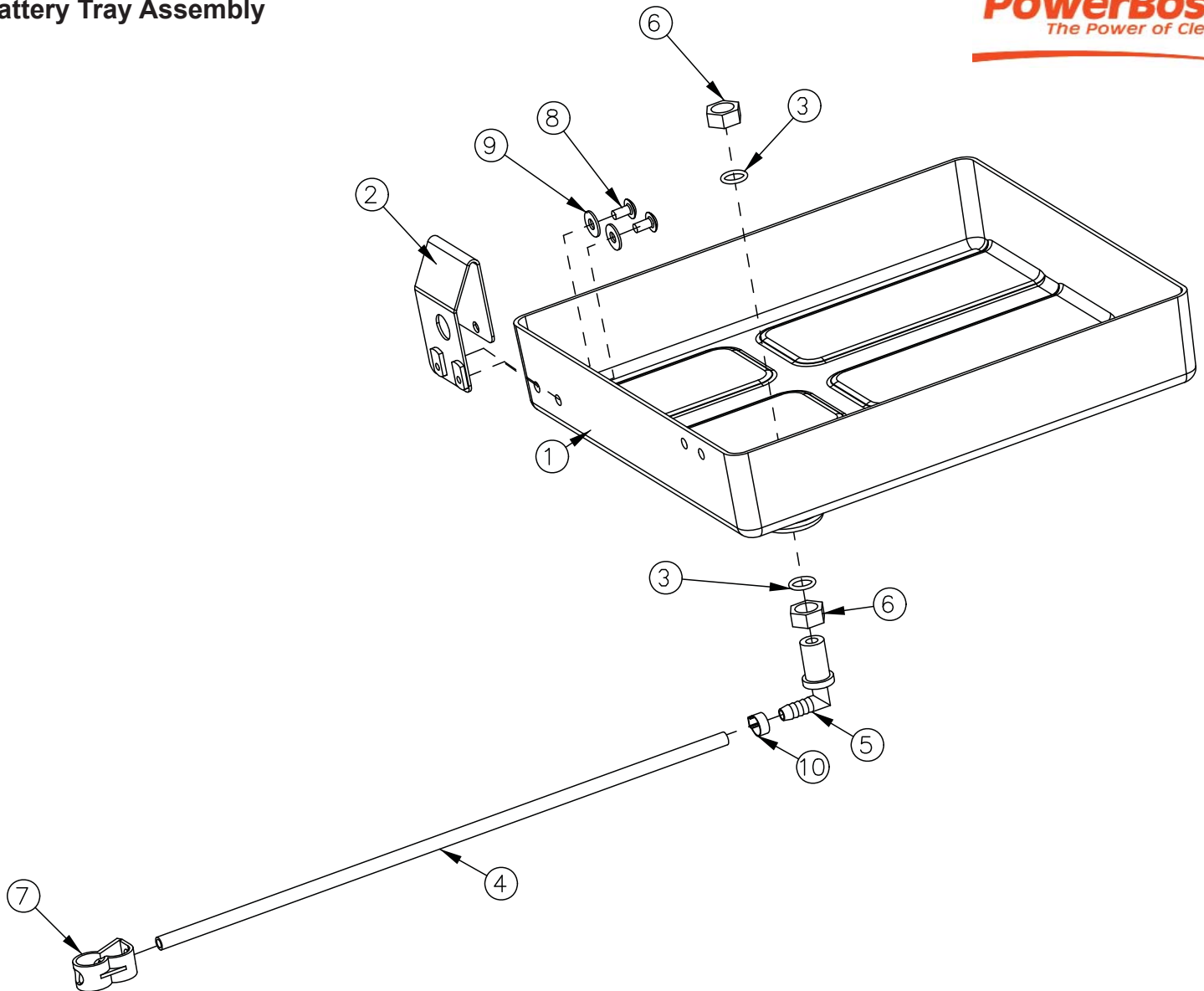

BILL OF MATERIAL - 172012			
ITEM	PART NO.	QTY	DESCRIPTION
1	172116	1	BATTERY BOX
2	172213	1	BKT, SPACER FOR BATTERIES
3	210414	2	O RING 2-113
4	260224	1	18" HOSE
5	320271	1	NOZZLE BODY-ELBOW
6	320272	2	NOZZLE BODY LOCKNUT
7	320273	1	HOSE SHUT-OFF CLAMP
8	710178	2	SCR-MC 1/4-20 X .50 TRUSS STPL
9	711575	2	WSR-FLT .31x.75x.06ST
10	828490	1	CRIMP CLAMP 140R

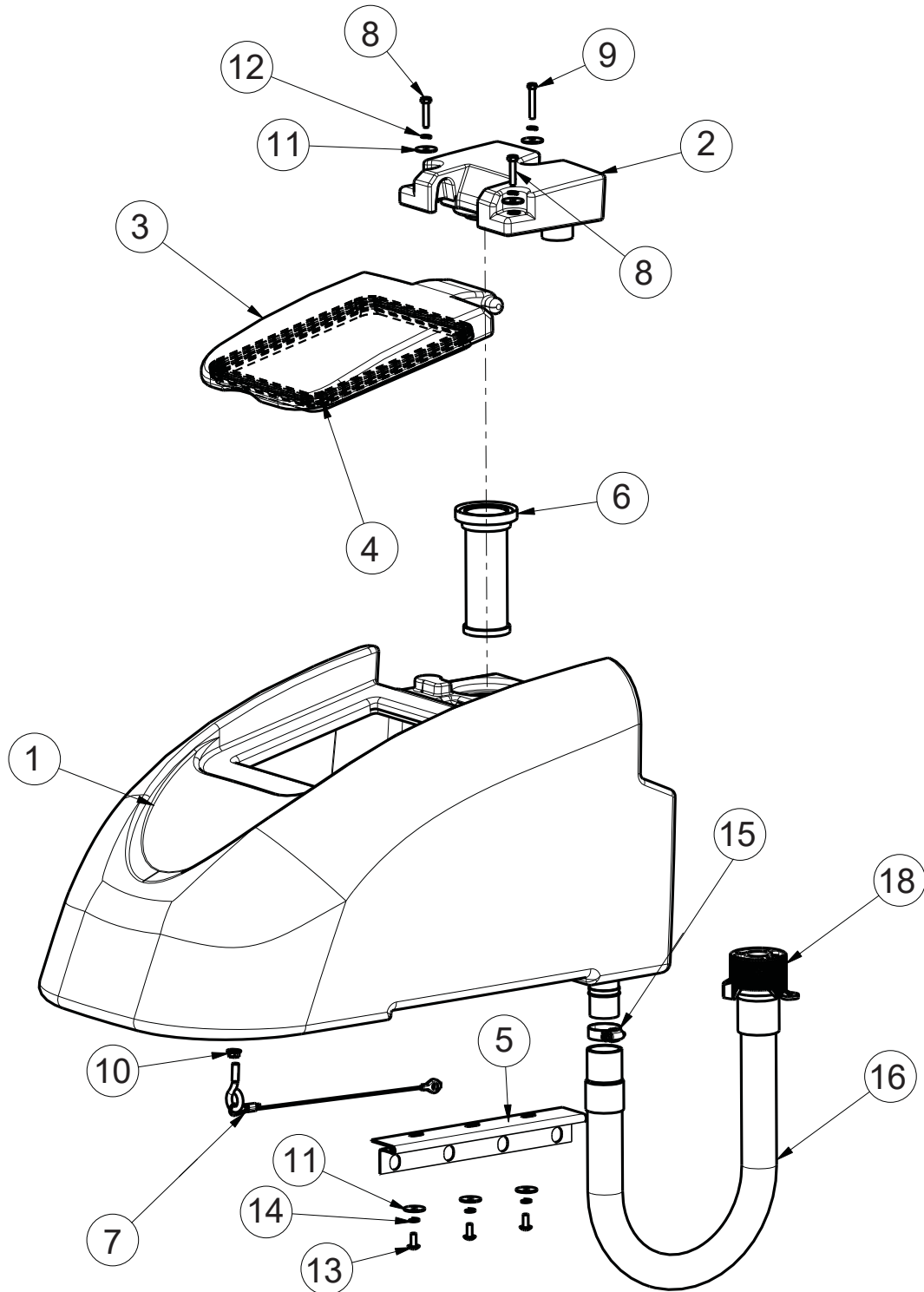

BILL OF MATERIAL - 172014HR

ITEM	PART NO.	QTY	DESCRIPTION
1	172004HR	1	RECOVERY TANK
2	172005HR	1	VACUUM MANIFOLD
3	172007	1	LID
4	172017	1	GASKET, LID
5	172049	1	HINGE, RECOVERY TANK
6	172132	1	FLOAT, SCREENED
7	172394	1	CABLE, REC TANK 12.0
8	711210	2	SCR-HH 1/4-20 X 1.25 ZP GR 5 FULL THRD
9	711212	1	SCR-HH 1/4-20 X 1.50 ZP GR 5
10	711379	1	NUT-FLANGED WIZZ 5/16-18 ZP
11	711519	6	WASHER-FLAT 1/4 X 1.00 X .06 ZP
12	711544	3	WASHER-LOCK 1/4 SPLIT ZP
13	712565	3	SCR-THMS 1/4-20 X .62 SS
14	712758	3	WASHER-LOCK 1/4 SPLIT SS
15	3303255	1	CLAMP-HOSE 1.75 DIA NOMINAL
16	97090096	1	DRAIN HOSE ASSY, RECOVERY TANK
17	15282072	1	REPLACEMENT O-RING (NOT SHOWN)
18	90304528	1	CAP

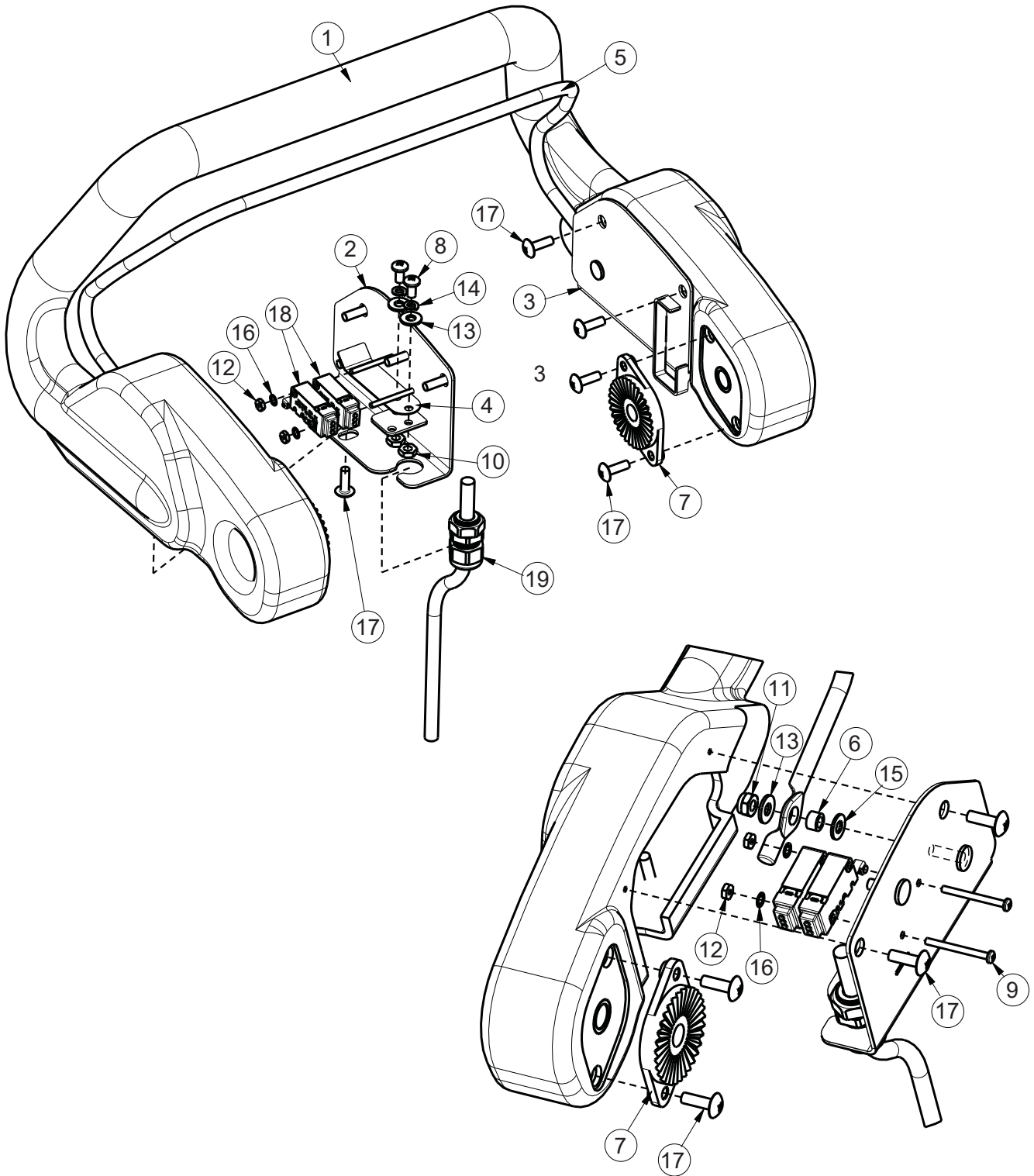

BILL OF MATERIAL - 172015			
ITEM	PART NO.	QTY	DESCRIPTION
1	172006	1	HANDLE
2	172053	1	BAIL PLATE WMT RH
3	172054	1	BAIL PLATE WMT LH
4	172057	2	LEAF SPRING
5	172059	1	BAIL, HANDLE
6	172074	2	SPACER, 5/16OD X 17GA, ALUM
7	270143	2	HANDLE PIVOT JAW
8	710353	4	SCR-MC RD HD 10-32 X.37 STL
9	710495	2	SCR-MC 4-40 X 1.25 STL Z
10	711310	4	NUT, HEX 10-32 ST PL
11	711350	2	NUT-NYLOC 10-32
12	711428	2	NUT-HEX 4-40
13	711503	6	WSR, FLAT#10
14	711543	4	WSR-HELICAL #10
15	712320	2	WSR-NYLON .22 X.45 X.04
16	712326	2	WSR-INT LOCK #4
17	712830	10	SCR-MC 10-24 X.62 STLZ TR HD
18	747603-3	2	SWITCH ASY, MICRO ROLLER W/PACK/CONDUIT
19	747715-1	1	CABLE ASY, 5 COND 18G TD

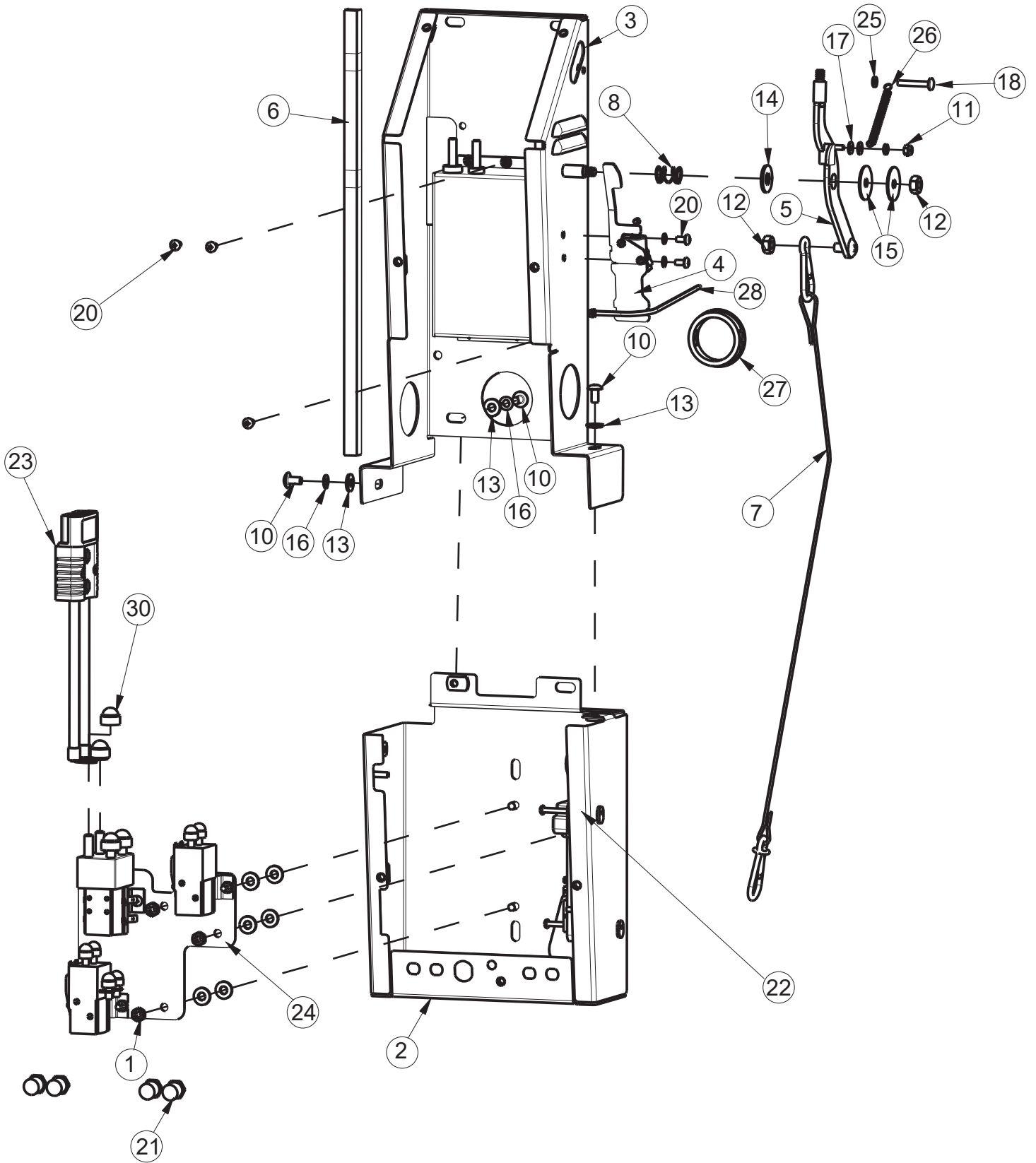

BILL OF MATERIAL - 172075-120			
ITEM	PART NO.	QTY	DESCRIPTION
1	369-416	3	NUT-HEX 1/4-20 ZP DOUBLE SERRATED
2	172077	1	ELEC BOX BOTTOM WMT
3	172088	1	ELEC BOX TOP WMT
4	172141	1	VAC SWITCH ASSY
5	172152	1	WELDMENT-VAC LEVER
6	172188	1	FOAM TAPE, 1/2" SQ X 16.5"
7	172381	1	SQUEEGEE CABLE ASSY
8	670093	1	SPRING-COMP .502 X .6 X 1 ZINC
9	710035	2	SCR-PHMS 8-32 X 1.125 ZP
10	710178	3	SCR-THMS 1/4-20 X .50 ZP
11	711372	1	NUT-NYLOC 8-32 ZP
12	711383	2	NUT-HEX 5/16-18 ZP REVERSE LOC
13	711505	9	WASHER-FLAT 1/4 ZP
14	711508	1	WASHER-FLAT 3/8 X 1.00 X .08 ZP
15	711516	2	WASHER-FLAT 5/16 X 1.25 X .05 ZP
16	711544	2	WASHER-LOCK 1/4 SPLIT ZP
17	712320	2	WASHER-FLAT 20 X .45 X .048 NYLON
18	712533	1	SCR-PHMS 10-24 X 1.25 SS
19	712770	5	WASHER-INT TOOTH LOCK #10 SS
20	712810	5	SCR-RHMS 10-24 X .37 ZP
21	742748	4	CIRCUIT BREAKER-BOOT
22	747608	1	I-DRIVE, 24V 70A PM CONTROL (SEE NOTES)
23	747637	1	WIRE ASY, MACHINE-BATTERY E1720
24	747670	1	ELECTRICAL PANEL ASY, E1720TD
25	760134	2	MOUNT RING
26	762084	1	SPRING-EXT .25OD X 2" F.L. MUSIC
27	762400	1	BUSH -HEYCO 1-5/8 X 2-1/8 X 29/64 2400 B
28	828062	1	CABLE TIE LARGE
29	957761	1	CHARGER, SIGNET HBF300-24 NEMA 5-15 PLUG
30	15592033	2	CAP, SAFETY NUT COVER M8

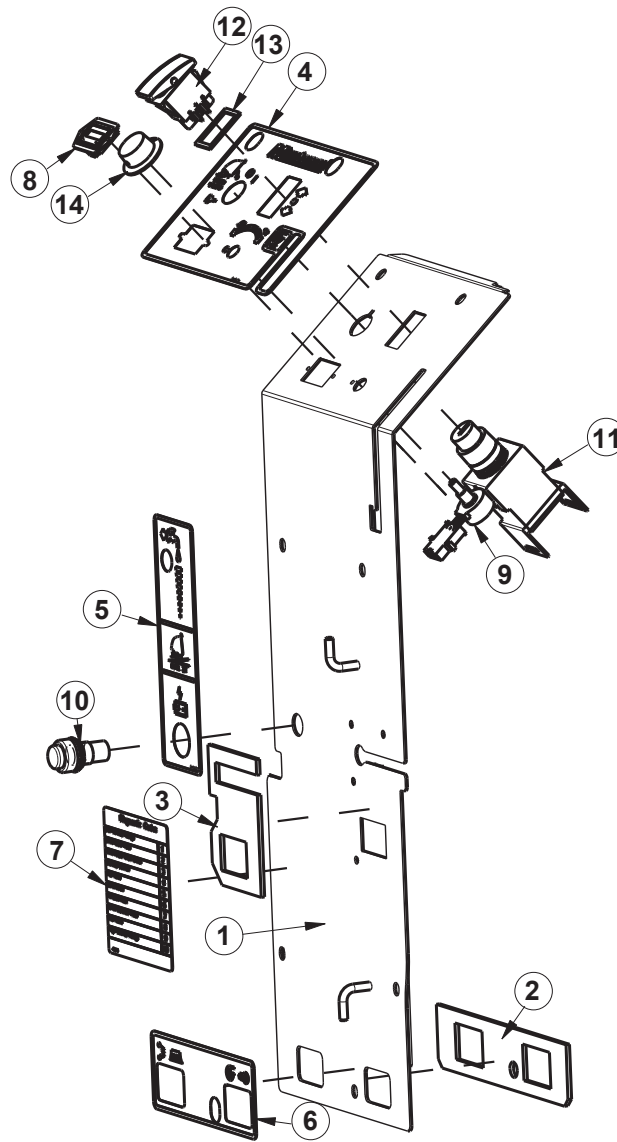

BILL OF MATERIAL - 172079PB

ITEM	PART #	QTY	DESCRIPTION	ITEM	PART #	QTY	DESCRIPTION
1	172182	1	TD COVER WMT	8	747011	1	GAUGE-BATTERY TRUCHARGE PGDT 36VDC
2	172193	1	GASKET, CB OUTLINE	9	747026	1	POTENTIOMETER ASSY, SPEED CONTROL
3	172194	1	GASKET, CHARGER CORD PLATE	10	747614	1	INDICATOR, BATTERY CHARGE STATUS
4	715682	1	DECAL, DASHBOARD PHOENIX 22 TD	11	747617-2	1	KEYSWITCH ASY, KEYSWITCH + HARNESS
5	715672	1	DECAL, CHARGE STATUS, SOLUTION CTRL	12	748201	1	SWITCH, DPDT ON/OFF/ON (SCV 2426)
6	715674	1	DECAL, TD CIRC BKRS, ES1720	13	748209	1	GASKET-FOR 2 POLE ROCKER SWITCHES
7	715699	1	DECAL, DIAGNOSTIC CODES, NARROW	14	809874	1	KNOB-SPEED CONTROL

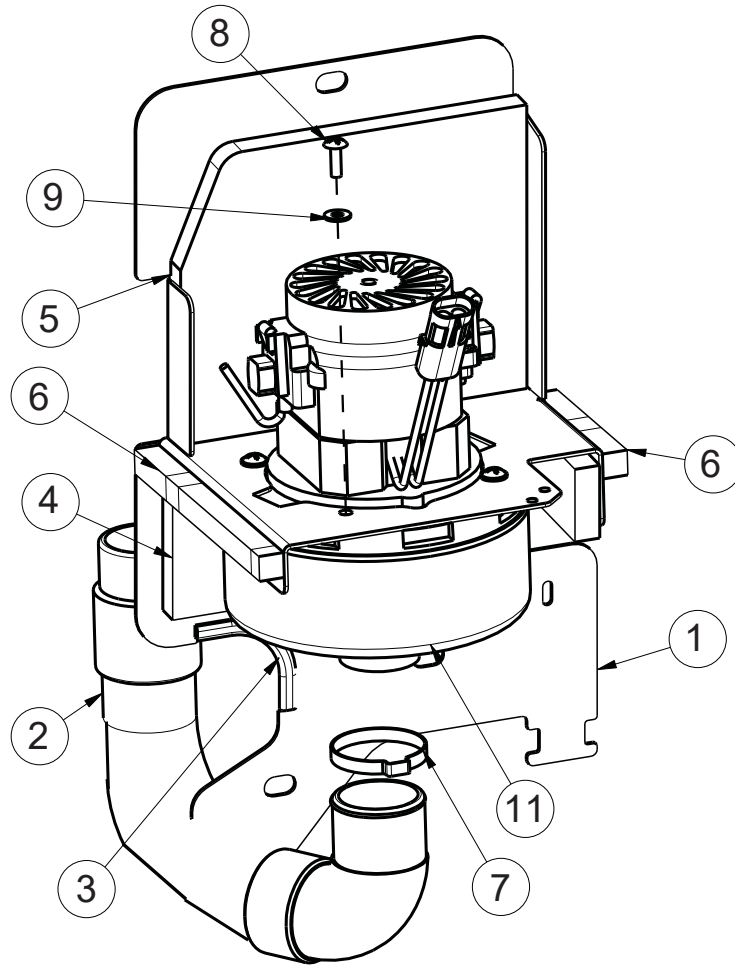

BILL OF MATERIAL - 172050

ITEM	PART NO.	QTY	DESCRIPTION
1	172045	1	VAC MOUNT WMT
2	172048	1	HOSE, STRETCH 13", 90 CUFF
3	172124	1	EDGE TRIM, .063 X 3.0, BLACK
4	172186	1	FOAM COVER FRONT 1, 1/2 THICK
5	172187	1	FOAM COVER FRONT 2, 1/2" THICK
6	172188	.5	FOAM TAPE, 1/2" SQ X 16.5"
7	450095	1	CLAMP-CRIMP 1.75" OD
8	711160	4	SCR-HI/LO 10 X .625 BLACK ZINC
9	711503	4	WASHER-FLAT #10 X .50 ZP
10	715967	1	DECAL - WARNING, DO NOT PICK UP (NOT SHOWN)
11	747607-1	1	VAC MOTOR ASY, 24V PERIF BYPASS

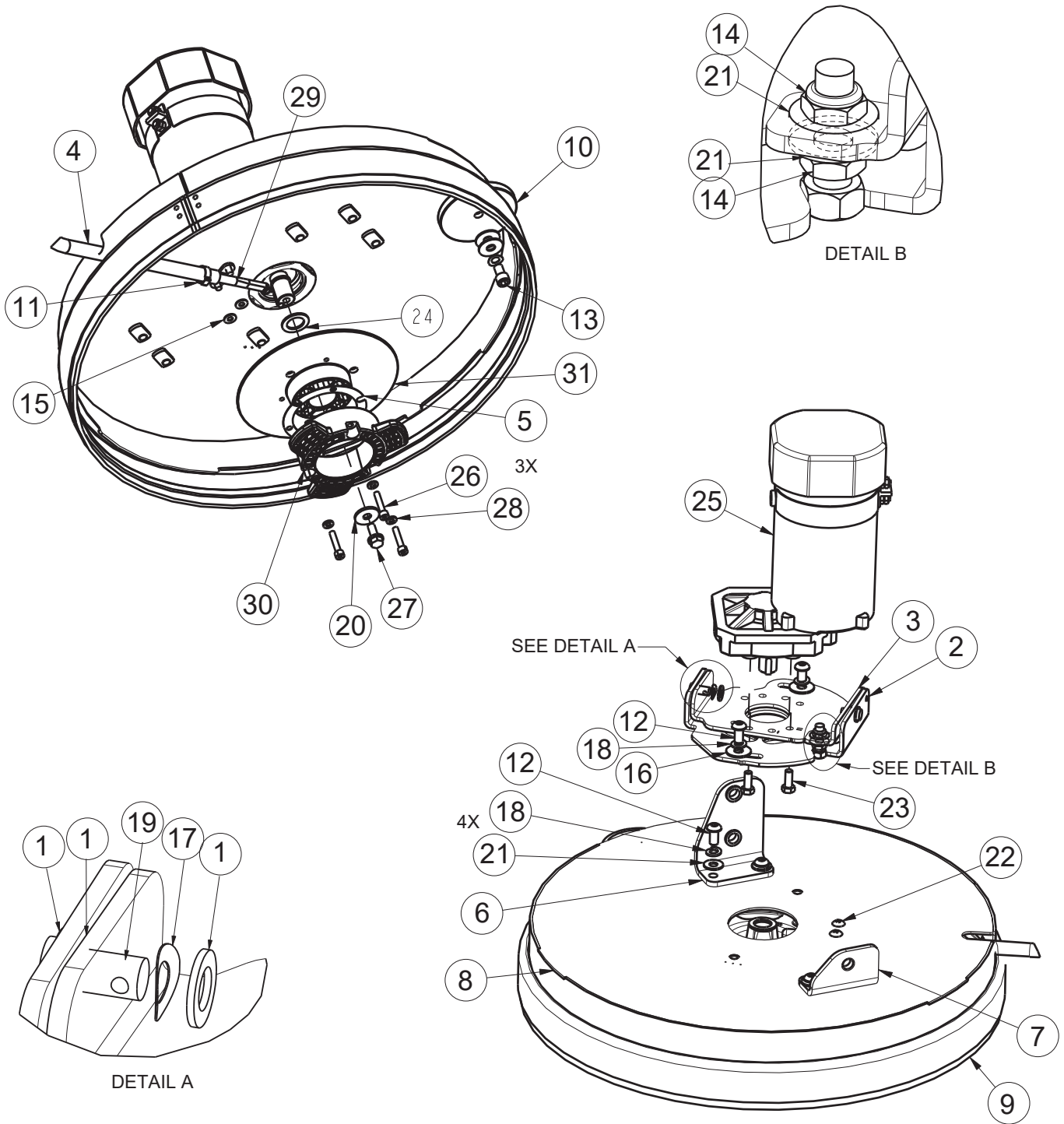

BILL OF MATERIAL - 172100TD			
ITEM	PART NO.	QTY	DESCRIPTION
1	81-166-A	6	SPECIAL WASHER
2	172040	1	DECK ANGLE ADJUST WMT
3	172044	1	PLATE, MOTOR MOUNT
4	172198	1	HOSE-NYLO REINF 3/8 X 22.5"
6	172296	1	BKT, E1720 DECK MOUNT RT
7	172297	1	BKT, E1720 DECK MOUNT LEFT
8	172375	1	DECK COVER WMT, 20"
9	172384	1	E20 FLOATING BRUSH DECK SKIRT
10	210153	1	ROLLER WHEEL
11	450076	1	CLAMP-HOSE 5/8 (.590-.791) SS
12	710990	6	SCR-BHSCS 3/8-24 X .75 ZP
13	710991	1	SCR-HH 3/8-24 X .62 ZP GR 5
14	711375	2	NUT-NYLOC 3/8-16 ZP
15	711504	2	WASHER-FLAT 1/4 SS
16	711507	4	WASHER-FLAT 3/8 X 1.12 X .06
17	711523	3	WASHER-WAVE .37 X .68 X .08
18	711546	6	WASHER-LOCK 3/8 SPLIT ZP
19	711679	2	PIN-CLEVIS 3/8 X .750 ZP
20	711855	1	WASHER-FENDER 3/8 X 1.12 X .10 ZP HARD
21	712301	6	WASHER-FLAT 3/8 X .87 X .06 ZP
22	712565	2	SCR-THMS 1/4-20 X .62 SS
23	717024	4	SCR-HH M8-1.25 X 20 ZP GRADE 8.8
24	717025	1	WASHER-FLAT 13/16 X 1.25 X .08 ZP
25	747600	1	MOTOR, 24VDC PM 600W
26	11127000	3	SCR-SHCS M6X30 SS, ISO4762
27	11717203	1	BLT-HH FLG M8X1.25X20 PRECOTE, ZD 10.9
28	12310256	3	WSR-FLT 6.4X12X1.6, SS DIN125
29	90311663	1	FITTING, WATER NOZZLE W/ MOUNT HOLES
30	90541814	1	DRIVE HUB, PLASTIC, 3-LOBE
31	172096MCH	1	HUB BASE MACHINED

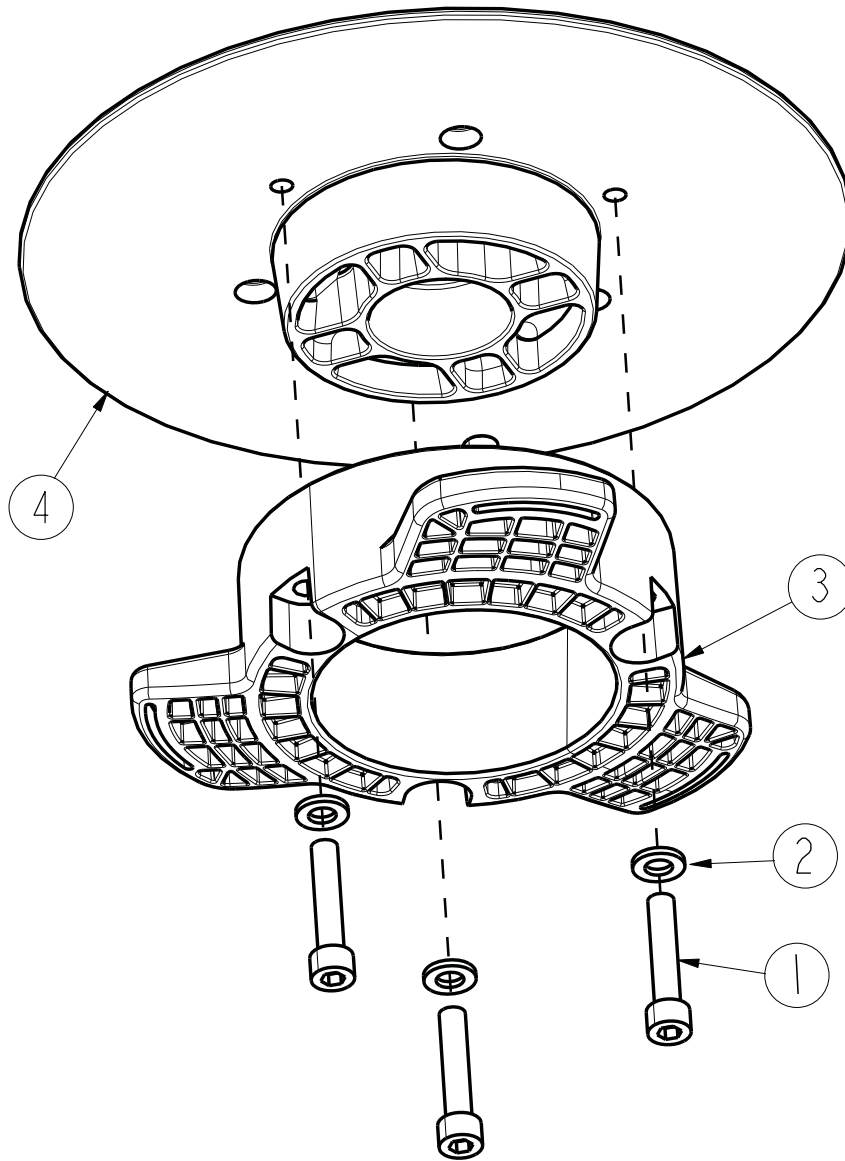

BILL OF MATERIAL - 172510			
ITEM	PART NO.	QTY	DESCRIPTION
1	11127000	3	SCR-SHCS M6X30 SS, ISO4762
2	12310256	3	WSR-FLT 6.4X12X1.6, SS DIN125
3	90541814	1	DRIVE HUB, PLASTIC 3 LOBE
4	172096MCH	1	BASE, DRIVE HUB WITH KEYWAY

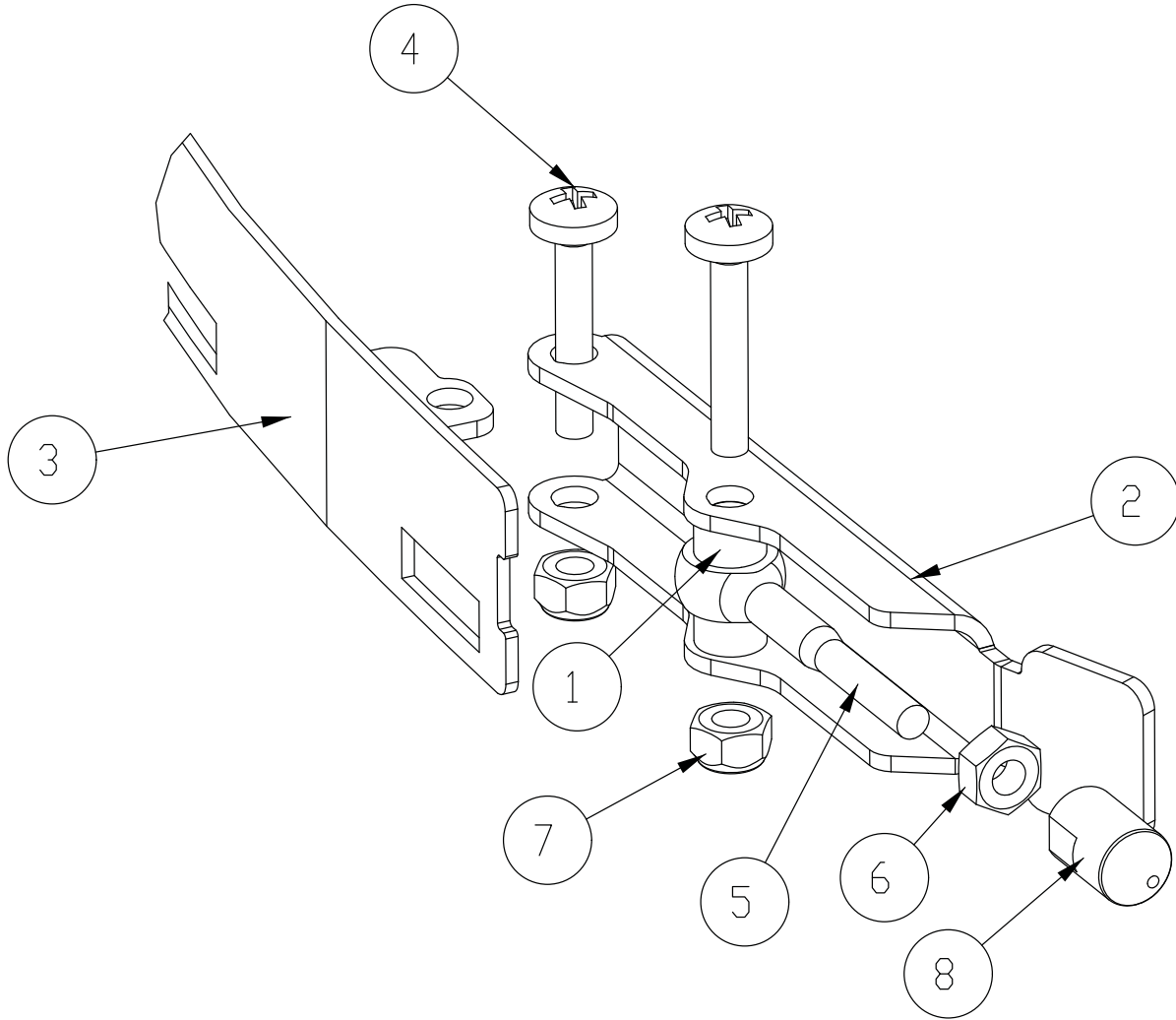

BILL OF MATERIAL - 172440			
ITEM	PART NO.	QTY	DESCRIPTION
1	172074	2	SPACER, 5/16OD X 17GA, ALUM
2	172234	1	LEVER, 90535758
3	172240	1	STRAP WMT, FRONT LEFT
4	11175494	2	SCR-MC M5 X 25 SS DIN7985
5	11518313	1	BLT-EYE M5 X 40 SS
6	12022430	1	NUT- HEX, M5, SS DIN934
7	12040283	2	NUT- HEX, M5 NYLON LOCK, SS DIN985
8	90513631	1	PIN, THD 90513631

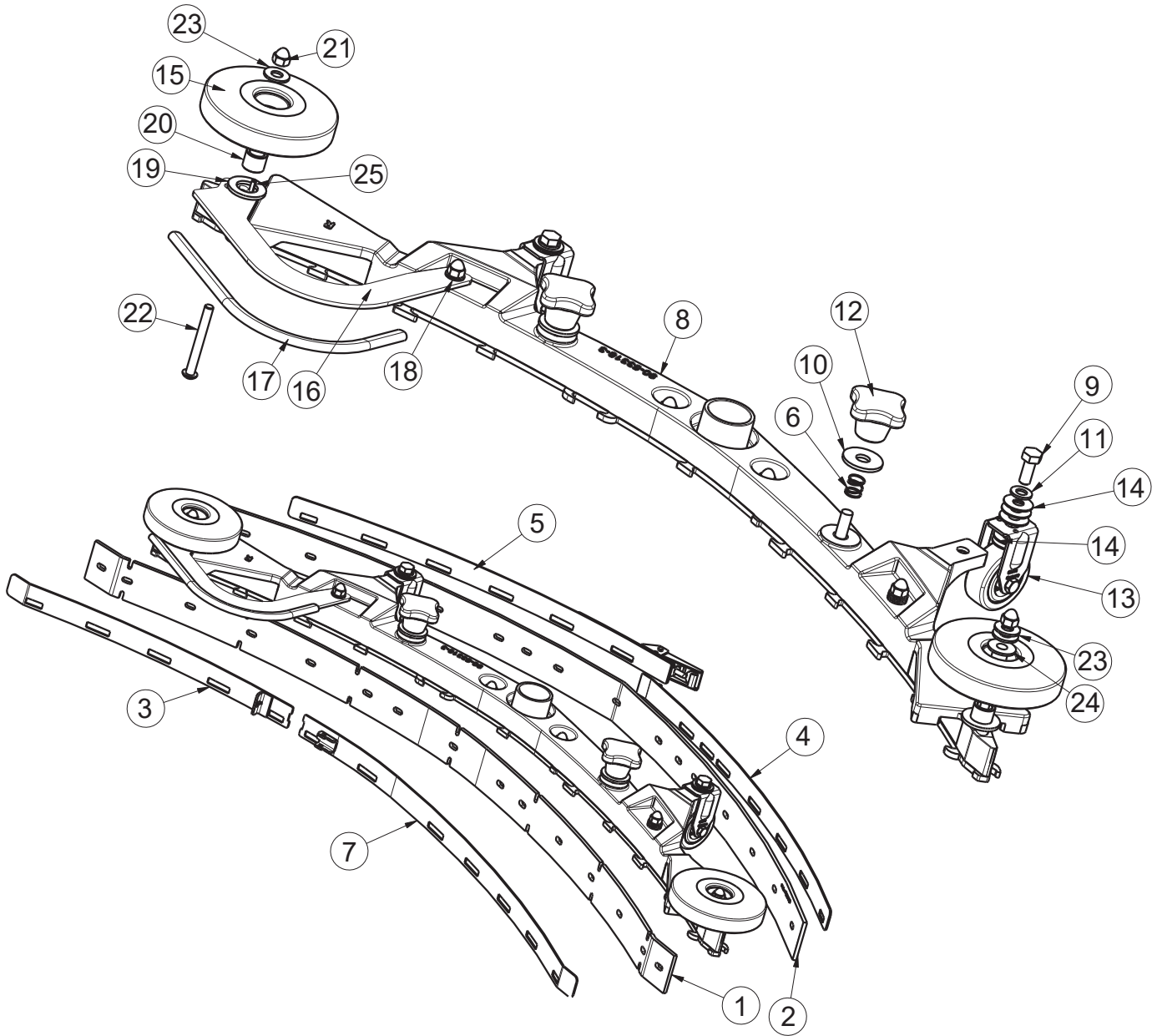

BILL OF MATERIAL - 172534			
ITEM	PART NO.	QTY	DESCRIPTION
1	172162	1	SQUEEGEE BLADE, FRONT 34" (860) 4MM PU
2	172163	1	SQUEEGEE BLADE, REAR 34" (860), 4MM PU
3	172241	1	STRAP WMT, FRONT RT - 34" (860) SQG
4	172245	1	STRAP WMT, REAR LEFT - 34" (860) SQG
5	172246	1	WELD-STRAP REAR RT - 34" (860) SQG
6	172429	2	SPRING, COMP .4 ID X .5FL SS
7	172440	1	STRAP W/ LATCH, FRONT LEFT, 34" SQG
8	172535	1	34" SQUEEGEE BASE ASM
9	717030	2	SCR-HH M8-1.25 X 20 SS
10	717040	2	WASHER-FLAT M10.5 X 30 X 2.5 SS
11	12310264	2	WSR-FLT M8.4 X 16 X 1.6 A2 SS 140HV DIN
12	17133026	2	STAR HANDLE, M10, BLACK
13	90513094	2	FIXED CASTER
14	90531112	10	WASHER-FLAT 8.3 x 22 x 1.00mm STAINLESS
15	90548397	2	ROLLER - PLASTIC, 100mm DIA. (4")
16	172271	1	BUMPER, 34" SQG
17	172274	1	EDGE TRIM, 5/16 X 10" BLACK
18	711504	5	WASHER-FLAT 1/4 SS
19	711527	2	WASHER-FLAT .63 X 1.12 X .09
20	430322	2	BUSHING-.435 X .625 X .50 ZINC
21	712591	6	NUT-ACORN 1/4-20 SS
22	712592	2	SCR-BHSCS 1/4-20 X 2.25 SS
23	712772	3	WASHER-FLAT .344 X .75 X .06 SS
24	840202	1	BUSHING-FLG .31 X .435 X .325 NYL
25	3400727	1	PIN-ROLL 1/8 X .50 ZINC

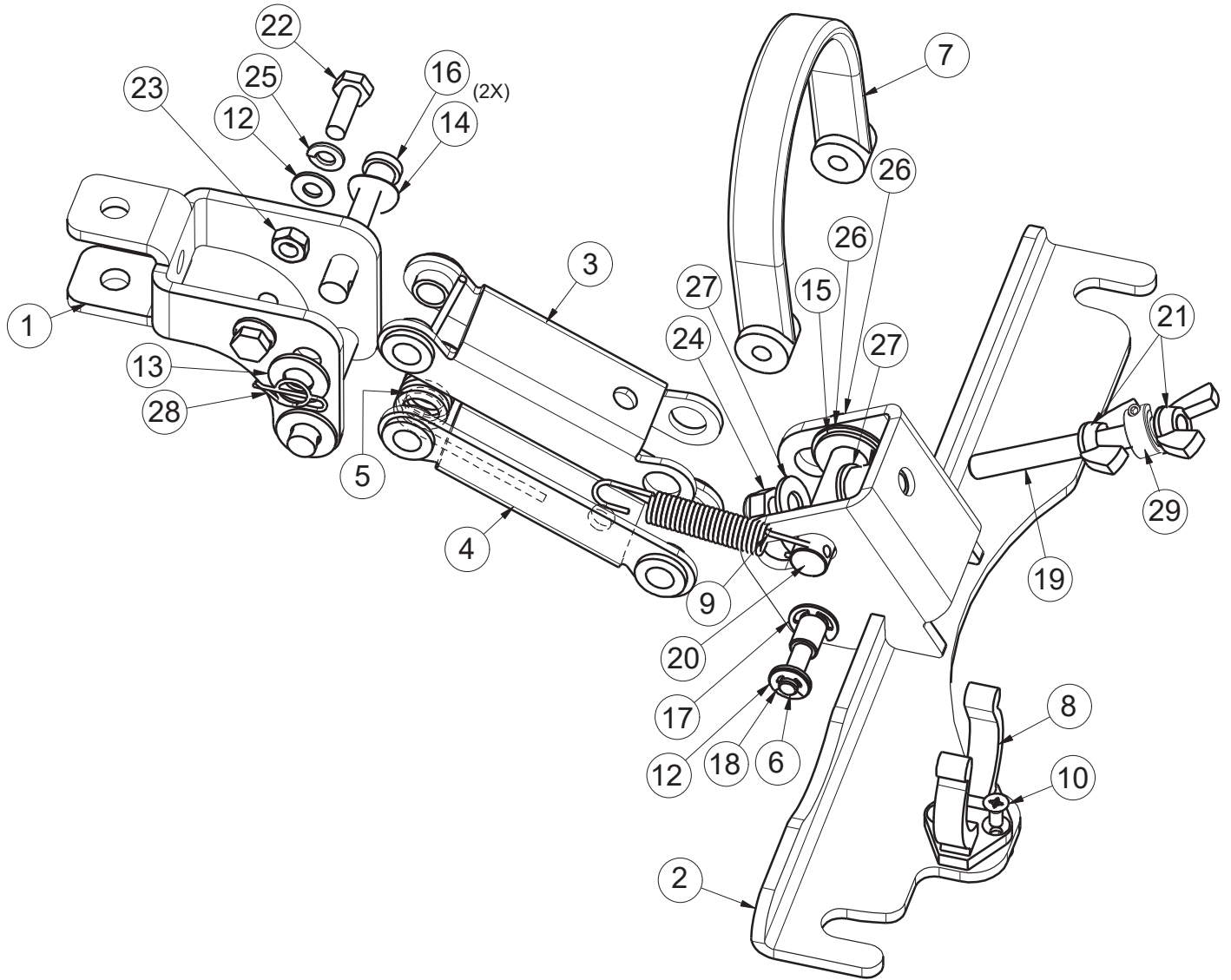

Squeegee Mechanism Assembly BOM

BILL OF MATERIAL - 172150

ITEM	PART NO.	QTY	DESCRIPTION
1	172134	1	BKT, SQG HINGE
2	172155	1	SQUEEGEE MOUNT WMT
3	172196	1	UPPER SQG LINK
4	172197	1	LOWER SQG LINK
5	172261	1	SPRING, TORSION 1720 SQG
6	172352	1	PIN, 3/8 X 3.0, SQG STRAP
7	172357	1	STRAP, 9" PU, BLACK
8	260579	1	CLIP-TOOL 1.5 INCH HOSE
9	430051	1	SPRING-RETURN .313 X .438 X 2.93 SS
10	710528	2	SCR-FHMS 8-32 X .37 BRASS
11	711420	1	NUT-JAM 5/16-18 ZP
12	711504	4	WASHER-FLAT 1/4 SS
13	712767	2	WASHER-FLAT .406 X .75 X .035 SS
14	711523	2	WASHER-WAVE .37 X .68 X .08
15	711592	2	WASHER-FLAT 1/2 X .90 X .064 NYLON
16	711678	2	PIN-CLEVIS 3/8 X 2 1/4 ZP
17	711717	2	RET RING-E EXT .37
18	711720	2	RET RING-E EXT .25
19	712147	1	ROD-THD 5/16-18 X 3.25 SS
20	712148	1	PIN-CLEVIS 1/2 X 2.25 WITH HOLE
21	712157	2	NUT-WING 5/16-18 SS
22	712562	2	SCR-HH 1/4-20 X .75, 18-8 SS
23	712665	2	NUT-HEX 1/4-20 SS
24	712683	1	NUT-NYLOC 5/16-18 SS
25	712758	2	WASHER-LOCK 1/4 SPLIT SS
26	712760	3	WASHER-FLAT .56 X 1.06 X .04 SS
27	712772	2	WASHER-FLAT .344 X .75 X .06 SS
28	3400125	1	RING-RUE 3/8
29	713528	1	COLLAR-THREADED CLAMP 5/16-18X5/16-BK OX

Wiring Diagrams

1

PAGE LAYOUT



PAGES GO TOGETHER AS SHOWN TO SEE THE ENTIRE SCHEMATIC AS ONE.

715678: DIAGNOSTIC CODE DECAL
 DIAGNOSTIC CODES: BATTERY GAUGE: 747011
 1 BAR : CHARGE BATTERIES
 2 BAR : DRIVE MOTOR CONNECTION
 3 BAR : DRIVE MOTOR SHORT CIRCUIT
 4 BAR : BATTERY LOCKOUT
 5 BAR : NOT USED
 6 BAR : DRIVE INHIBIT
 7 BAR : THROTTLE FAULT
 8 BAR : DRIVE CONTROLLER FAULT
 9 BAR : NOT USED
 10 BAR : EXCESSIVE BATTERY VOLTAGE

ELECTRICAL
 BOX COVER
 ASSEMBLY
 172079

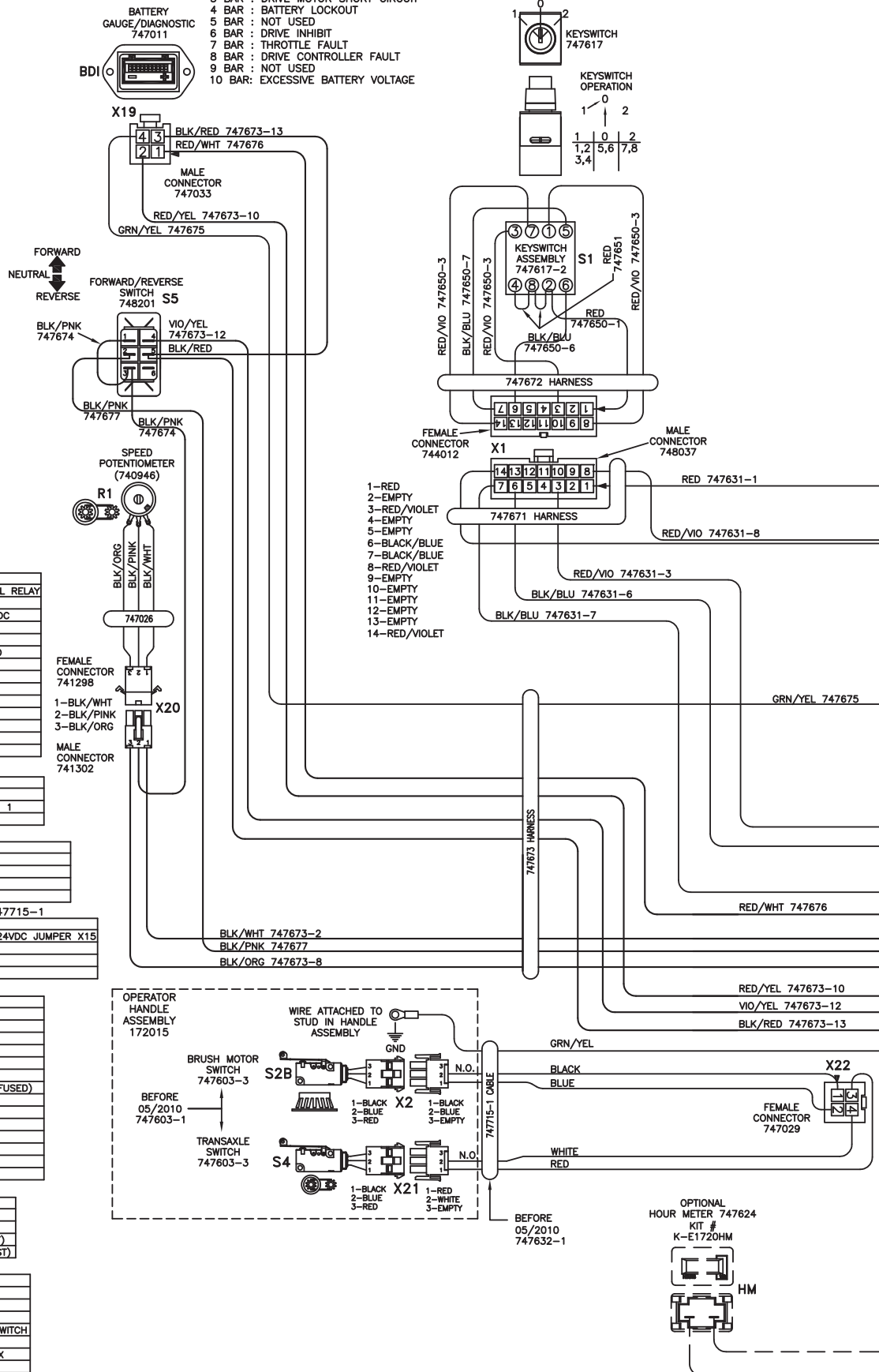

X1: MAIN KEYSWITCH ASSEMBLY: 747617-1

PIN #	COLOR	WHERE TO/FROM
1	RED	X13: BATTERY CHARGER INTERNAL RELAY
2	-	-
3	RED/VIOLET	BRUSH MOTOR RELAY COIL: 24VDC
4	-	-
5	-	-
6	BLACK/BLUE	BRUSH RELAY NORMALLY CLOSED
7	BLACK/BLUE	BRUSH UNLOAD SWITCH P:B
8	RED/VIOLET	X12: MAIN RELAY COIL: 24VDC
9	-	-
10	-	-
11	-	-
12	-	-
13	-	-
14	RED/VIOLET	X12: MAIN RELAY COIL: 24VDC

X20: SPEED POTENTIOMETER: 747026

PIN #	COLOR	WHERE FROM/TO
1	BLACK/WHITE	X23: I-DRIVE P:2
2	BLACK/PINK	FORWARD/REVERSE SWITCH 3 TO 1
3	BLACK/ORANGE	X23: I-DRIVE P:8

X22: OPERATOR HANDLE CABLE: 747715-1

PIN #	COLOR	WHERE FROM/TO
1	BLUE	X22.1 TO S2B:X2.B
2	BLACK	X22.2
3	RED	X22.3 TO S4:X21.A
4	WHITE	X22.4 TO S4:X21.B

X22: CONNECTOR TO OPERATOR HANDLE CABLE: 747715-1

PIN #	COLOR	WHERE FROM/TO
1	RED/VIOLET	X22.1 TO X10 JUMPER K2:COIL:24VDC JUMPER X15
2	RED/VIOLET	X22.2 TO X11 TO S2A:X7.A
3	BLACK/PINK	X22.3 TO A1:X23.1
4	BLACK/PINK	X22.4 TO S5.2

X23: I-DRIVE HARNESS: 747673

PIN #	COLOR	WHERE TO/FROM
1	BLACK/PINK	X22: P:3
2	BLACK/WHITE	X20: SPEED POT P:1
3	EMPTY	-
4	EMPTY	-
5	RED/WHITE	JUMPER TO P:7 (ON/OFF)
6	BROWN/GREEN	JUMPER TO P:14. (INHIBIT 1)
7	RED/WHITE	JUMPER TO P:5 (24VDC IDRIVE FUSED)
8	BLACK/ORANGE	X20: SPEED POT P:3
9	EMPTY	-
10	RED/YELLOW	X19: BATTERY GAUGE P:2
11	EMPTY	-
12	VIOLET/YELLOW	FORWARD/REVERSE SWITCH 4
13	BLACK/RED	JUMPER TO FOR/REV SWITCH 5
14	BROWN/GREEN	JUMPER TO P:6. (INHIBIT 2)

BATTERY CHARGER: 957761 or 957760

PIN #	COLOR	WHERE TO/FROM
X13	RED	X13: KEYSWITCH P:1
X14	BLACK	X14: CONTROL CB 4.0A
14GA	RED	MAIN RELAY + (REAR LEFT POST)
14GA	BLACK	MAIN RELAY - (FRONT LEFT POST)

OTHER WIRE COLORS

PIN #	COLOR	WHERE TO/FROM
1	RED	BATTERY 24VDC: +
2	BLACK	BATTERY OVDC: -
3	GREEN/YELLOW	GROUND
4	BLACK/BLUE	BRUSH UNLOAD CIRCUIT
5	RED/BLACK	BRUSH UNLOAD CIRCUIT:MICRO SWITCH
6	RED/VIOLET	24VDC AFTER MAIN KEYSWITCH
7	GREY/RED	OPTIONAL POWER 24VDC: 3A MAX
8	GREY/BLACK	OPTIONAL POWER OVDC: 3A MAX

2

ELECTRICAL BOX ASSEMBLY
172075-120
172075-230

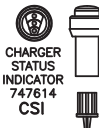

120VAC 60Hz or 230VAC 50Hz (different plug) CORD 748680CE 748680 (UK)

CHARGER 957760 IEC60320 C14

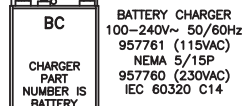

- CHARGING PROFILES
1. 956712 12V 105Ah-FLOODED(-1)
 2. 956140 12V 140Ah-FLOODED(-2)
 3. 956135 12V 135Ah-GEL(G-3)
 4. 956100 12V 100Ah-GEL(G-4)



RELAY NUT COVER
MAIN RELAY M8 15592033 (4)
VACUUM RELY M6 15592025 (2)
BRUSH MOTOR RELAY M6 15592025 (4)

*RELAY TERMINALS ARE METRIC
MAIN RELAY:M8 TORQUE TO 8-9.5Nm
VACUUM & BRUSH RELAY:M6 TORQUE TO 3.6-3.9Nm

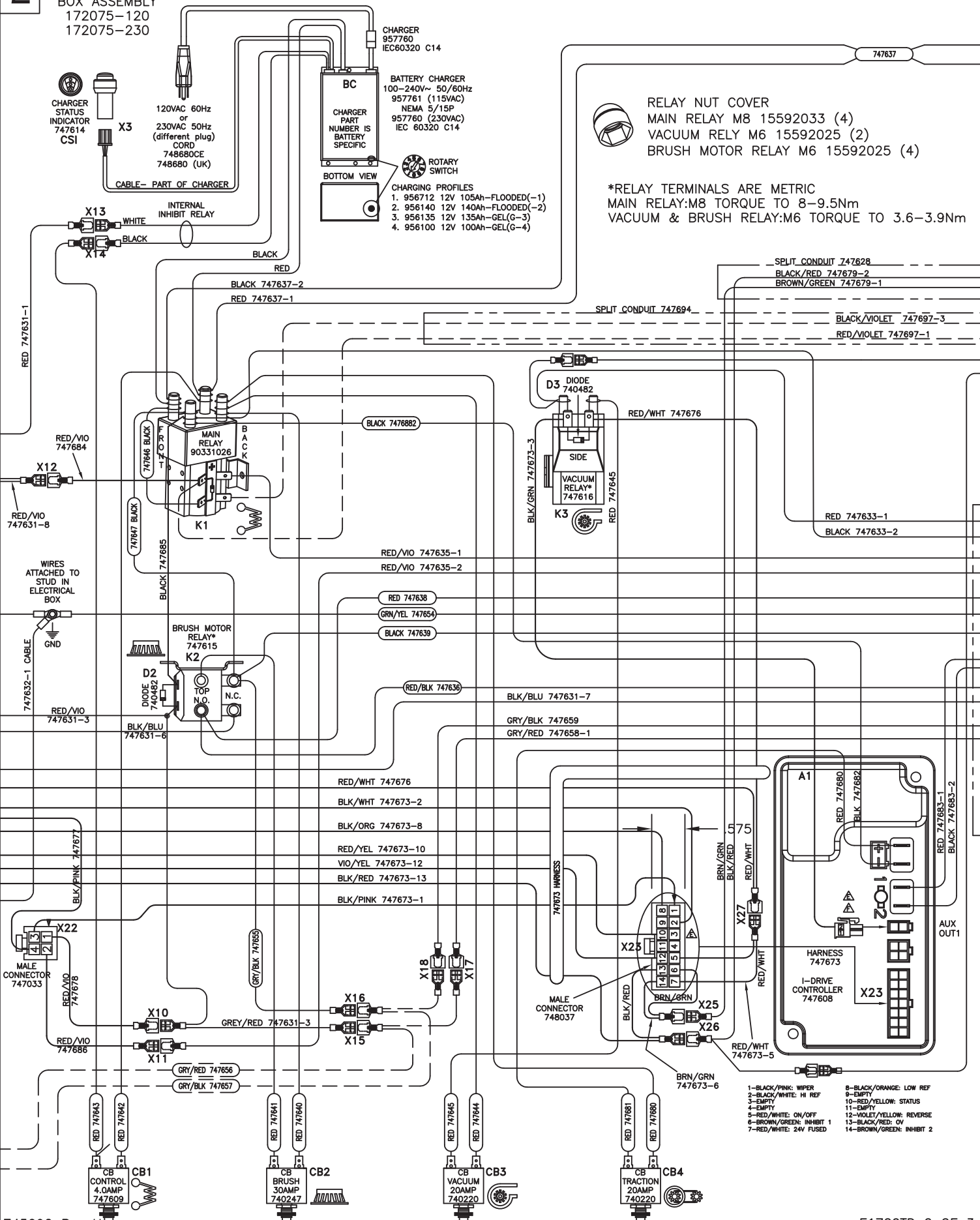

- | | |
|--------------------------|---------------------------|
| 1-BLACK/PINK: WIPER | 8-BLACK/ORANGE: LOW REF |
| 2-BLACK/WHITE: HI REF | 9-EMPTY |
| 3-EMPTY | 10-RED/YELLOW: STATUS |
| 4-EMPTY | 11-EMPTY |
| 5-RED/WHITE: ON/OFF | 12-VIOLET/YELLOW: REVERSE |
| 6-BROWN/GREEN: INHIBIT 1 | 13-BLACK/RED: OV |
| 7-RED/WHITE: 24V FUSED | 14-BROWN/GREEN: INHIBIT 2 |

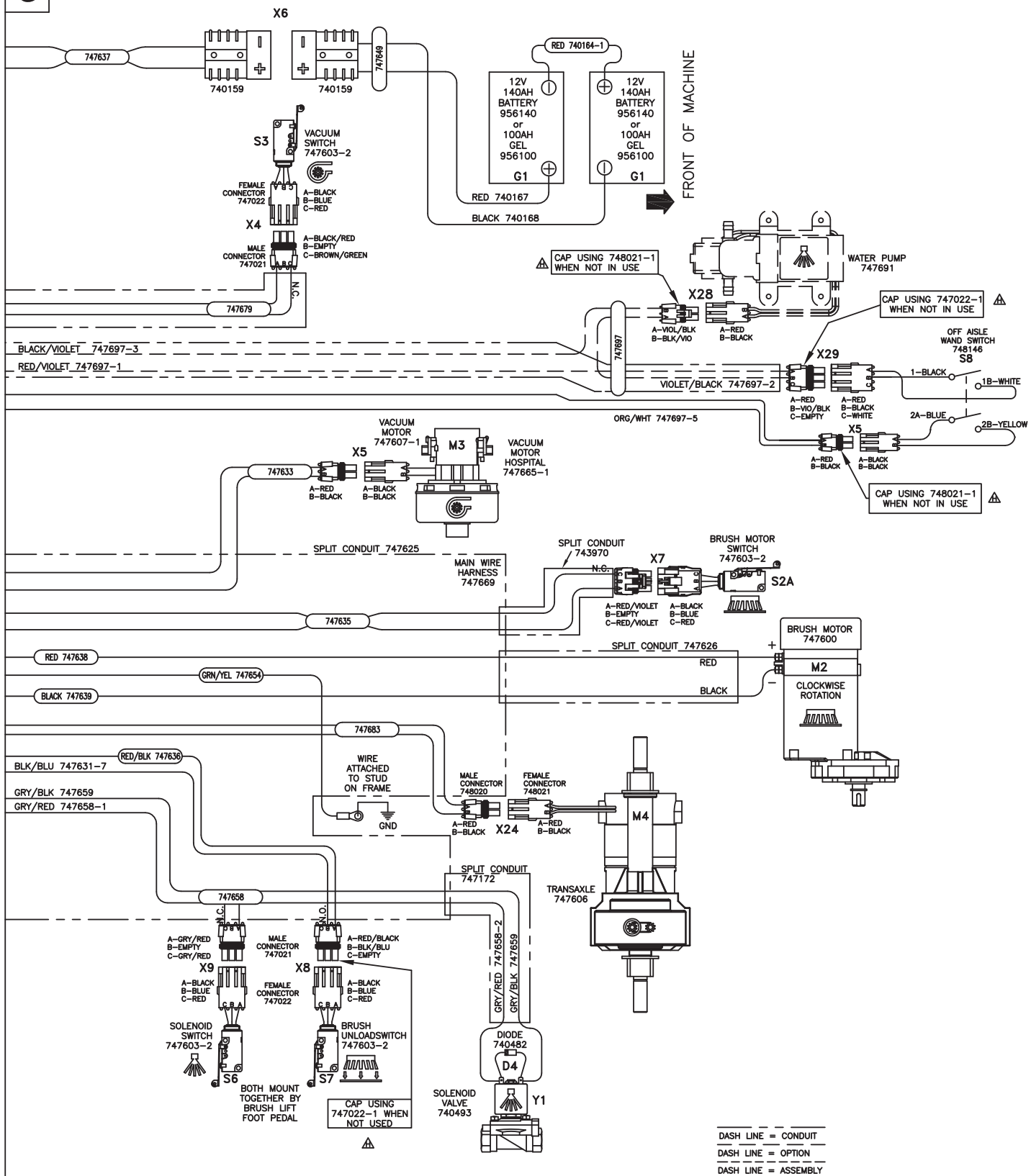

Revision J
Effective January 2014
PowerBoss Made Simple Industrial Limited Warranty

Minuteman International owner of PowerBoss warrants to the original purchaser/user that the product is free from defects in workmanship and materials under normal use. PowerBoss will, at its option, repair or replace without charge, parts that fail under normal use and service when operated and maintained in accordance with the applicable operation and instruction manuals. All warranty claims must be submitted through and approved by factory authorized repair stations.

This warranty does not apply to normal wear, or to items whose life is dependent on their use and care. Parts not manufactured by PowerBoss are covered by and subject to the warranties and/or guarantees of their manufacturers. Please contact Minuteman International for procedures in warranty claims against these manufacturers.

Special warning to purchaser -- Use of replacement parts not manufactured by PowerBoss or its designated licensees, will void all warranties expressed or implied. A potential health hazard exists without original equipment replacement.

All warranted items become the sole property of Minuteman International or PowerBoss or its original manufacturer, whichever the case may be.

PowerBoss disclaims any implied warranty, including the warranty of merchantability and the warranty of fitness for a particular purpose. PowerBoss assumes no responsibility for any special, incidental or consequential damages.

This limited warranty is applicable only in the U.S.A. and Canada, and is extended only to the original user/purchaser of this product. Customers outside the U.S.A. and Canada should contact their local distributor for export warranty policies. PowerBoss is not responsible for costs or repairs performed by persons other than those specifically authorized by PowerBoss. This warranty does not apply to damage from transportation, alterations by unauthorized persons, misuse or abuse of the equipment, use of non-compatible chemicals, or damage to property, or loss of income due to malfunctions of the product. If a difficulty develops with this machine, you should contact the dealer from whom it was purchased.

This warranty gives you specific legal rights, and you may have other rights, which vary from state to state. Some states do not allow the exclusion or limitation of special, incidental or consequential damages, or limitations on how long an implied warranty lasts, so the above exclusions and limitations may not apply to you.

	Travel *	Labor	Parts	Engine	Extended Warranty	Costs
Walk Behind						****
Battery Sweepers	90 Days	12 months	12 months	N/A	N/A	-
IC Sweepers	90 Days	12 months	12 months	Through Eng. Mfg.	N/A	-
Battery Scrubbers	90 Days	24 months	36 months	N/A	N/A	-
Riders						
Battery Scrubbers	90 Days	24 months	36 months or 2000 hr.	N/A	36 months parts + 24 labor (or 3000 Hours)	5%
IC Sweeper/Scrubbers 82 & 90	90 Days	6 months	24 months or 2000 hr.	24 months or 3000 hrs**	36 months parts + 24 months labor (or 3000 Hours) + 180 days travel	5%
I.C. Sweepers 9X, 10X	90 days	6 months	48 months or 3000 hrs.	60 months or 3000 hrs**	48 months parts + 24 months labor (or 3000 Hours) + 180 days travel	5%
NAUTILUS Scrubber	180 Days	24 months	36 months or 2000 hr.	36 months or 2000 hrs**	48 months parts + 24 months labor (or 3000 Hours) + 180 days travel	3%
All Rider, I.C. (excluding APEX series)					Bumper to Bumper 5000 hr max. 48 months parts, 48 months labor, 180 days travel	8%
Exceptions						
Apex Series Sweeper	90 Days	12 months	12 months or 1000 hr.	12 months or 1000 hrs**	24 months parts + 24 months labor (or 2000 Hours)	5%
6X Sweeper	90 Days	6 months	24 months or 2000 hr.	24 months or 2000 hours**	36 months parts + 24 months labor (or 3000 Hours) + 180 day travel	5%

Tank Bladders Eight years/ no additional labor
Polyethylene plastic tanks Ten years/ no additional labor
Batteries 0-3 months full replacement, 4-12 prorated credit
Chargers One-year replacement
Aftermarket Replacement parts Ninety days from date of purchase

*Two-Hour Cap Per Service Call

**Through Engine Manufacturer. See Section 3 of Warranty Manual for Engine Warranty Exceptions

*** Based Upon Dealer's Certification Status:

Extended Warranty MUST Be Signed Up Within 30 Days of Delivery to End User
 (Dealer Has 1Year From Receiving Machine To Sign Up For Extended Warranty)

***All above labor and travel reimbursed at 65% or 75% of the published shop rate.

“The Power of Clean”

**PowerBoss® is a Full Line Manufacturer of Sweepers and Scrubbers,
for Industrial Facilities.**

PowerBoss®, Minuteman International, Inc. 14N845 U.S. Route 20 Pingree Grove, Illinois 60140
Phone: 800-323-9420 www.PowerBoss.com Email: tech@powerboss.com
A Member of the Hako Group